

Environmental Air Filters

Reservoir Equipment



When it comes to 'green' breathing

Ecology and Economy

EAB Series and ABL Series environmental air filters provide hydraulic system designers, OEM's and end users eco-friendly advantages for a wide range of mobile applications such as forestry equipment and industrial uses such as industrial power units.



Contact Information:

Parker Hannifin
Hydraulic Filter Division Europe

**European Product
Information Centre**
Freephone: 00800 27 27 5374
(from AT, BE, CH, CZ, DE, EE, ES,
FI, FR, IE, IT, PT, SE, SK, UK)
filtrationinfo@parker.com

www.parkerhfde.com

Product Features:

- EAB Series – air flows up to 1500 l/min. Visual gauge option.
- ABL Series – 3 micron Abs. LEIF[®] element. 2 sizes.
- 2 environmental breather options suitable for most applications.

EAB Series

Reservoir Equipment

Typical Applications



- Agricultural machines
- Articulated dump trucks
- Forestry equipment
- Wheeled loaders
- Lubricating systems
- Excavators
- Mobile cranes
- Industrial power units

Technical Data

The filter has been designed to achieve a low pressure drop and high dirt holding capacity with airflows up to 1500 l/min. A compact EAB10 with airflows up to 1000 l/min is also available.

Construction:

Glass reinforced composite housing with Eco-element.

Filter media options:

P020: High quality polyester media. 2µm (abs).

C015: Polyester media with water-resistant layer. 1.5µm (abs)

Q010: Glass fibre media. 1.0µm (abs)

Mounting options:

With 6 screws. Includes machine and plate screws, a strainer and gaskets.

External threads G^{3/4}" , G1".

Internal thread G^{3/4}".

Options:

Visual gauge type vacuum/pressure indicator.

Overpressure valve, pressure setting 0.2 bar.

EAB10 cannot be specified with an overpressure valve and vacuum/pressure gauge at the same time.

Advantages of the EAB filters:

Easy maintenance.

Indicator states the need for element change.

Quick and easy element change (no tools required).

Environmentally friendly:

EAB elements contains no metal parts: therefore it can be crushed and burned minimising the volume of waste material.

Other features:

The optional indicator is located in a safe place inside the housing.

Housing includes mounting holes for a padlock, which allows you to increase the security against theft and vandalism.

Suitable for temperatures -20°C to +80°C.

Pressure Drop Curves

$\Delta p_{total} = \Delta p_{housing} + \Delta p_{element}$. The recommended level of the initial pressure drop for this filter is max 0.02 bar (2.0 kPa).

EAB10 Housing Only

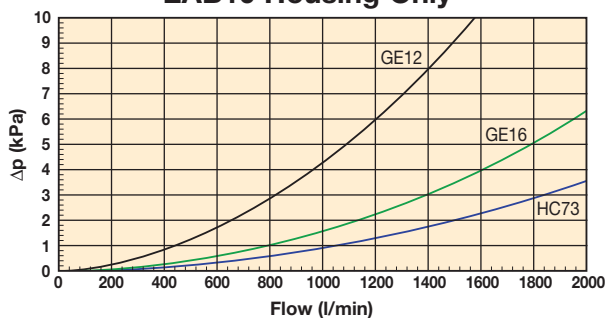

EAB10 Elements

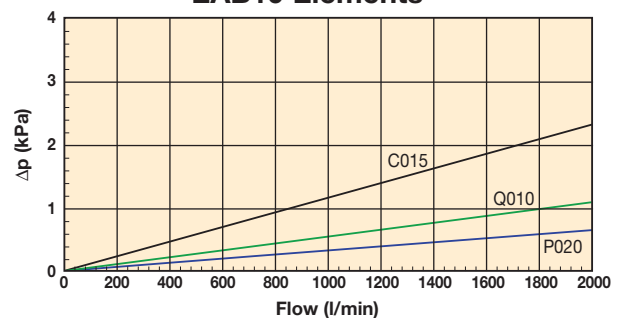

EAB20 Housing Only

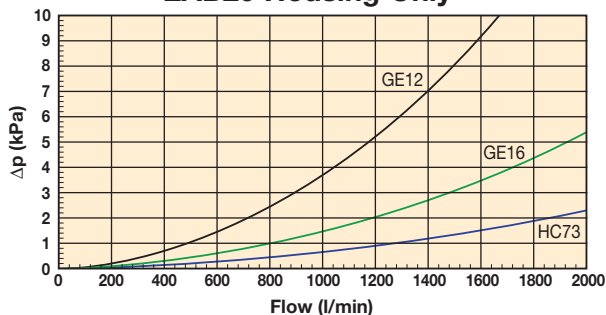

EAB20 Elements

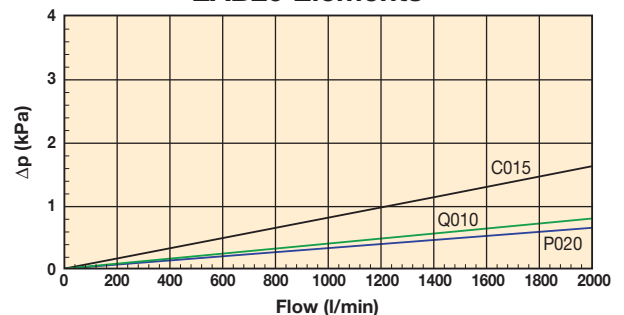

Specification

EAB10

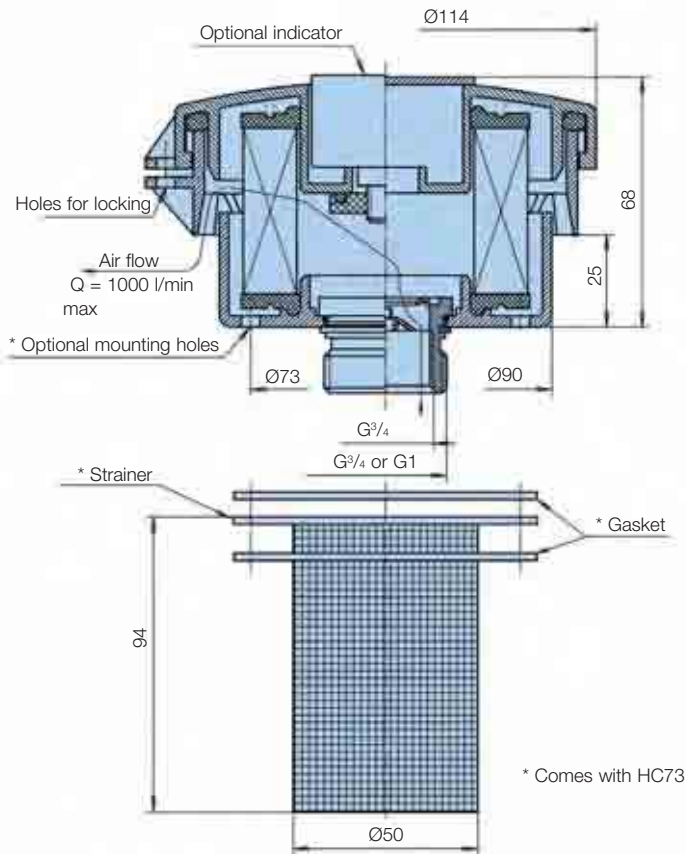

EAB20

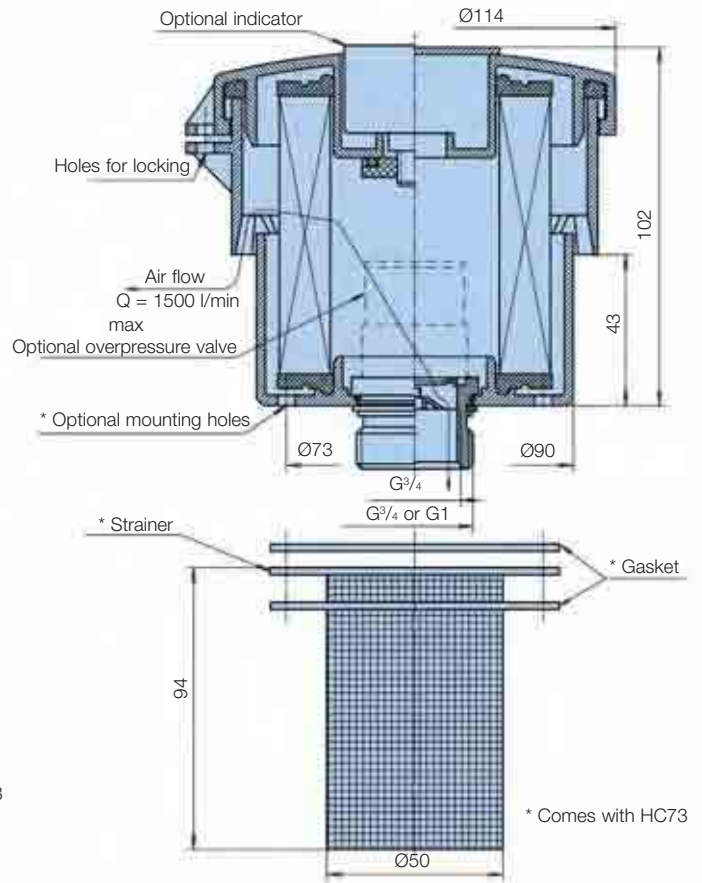

NOTICE!

Air filters are an essential part of the system and the element needs to be replaced regularly.

6 hole fixing mounting dimensions

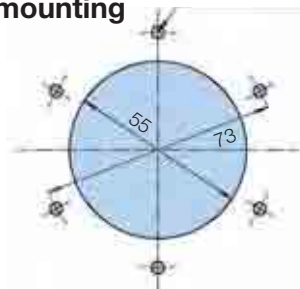

Mounting	Code
6 mounting holes	HC73
G1 external	GE16
G3/4 external	GE12
G3/4 internal	GS12

Note: Optional indicator scale $-0.35/-0.2$ to $+0.2/+0.35$ bar.
 Note: Optional mounting holes act as drain holes (except the HC73) in combination with a CO15 element.

EAB Series

Reservoir Equipment

Ordering Information

Standard products table

Part number	Supersedes	Model	Media	Mounting	Overpressure valve	Indicator	Replacement elements
EAB20P020HC73V2	EAB20P020HC73-V2	EAB20	P020	HC73	V2		EAC20P020
EAB10P020HC73	N/A	EAB10	P020	HC73			EAC10P020
EAB20P020HC73	N/A	EAB20	P020	HC73			EAC20P020
EAB20P020GE16	N/A	EAB20	P020	GE16			EAC20P020
EAB20P020HC73A	EAB20P020HC73-A	EAB20	P020	HC73		A	EAC20P020

Product configurator

Product number	Media options		Mounting options		Overpressure valve options		Indicator options	
EAB20	P020	2µ abs polyester	HC73	6 hole fixing		No overpressure valve		No indicator
EAB10	C015	1.5µ abs water resistant	GE12	G ³ / ₄ external thread	V2	0.2 bar	A	Vacuum/pressure gauge
	Q010	1.0µ abs glass fibre	GE16	G1 external thread G ⁷ / ₈ internal				
			GS12	thread M33 x 2 external thread				
			ME33	thread				

Replacement elements

Product number	Media options	
EAC20	P020	2µ abs polyester
EAC10	C015	1.5µ abs water resistant
	Q010	1.0µ abs glass fibre

Note 1: Part numbers featured with bold highlighted codes will ensure a 'standard' product selection.

Note 2: For alternative part number options, consult Parker Filtration.

ABL Series

Reservoir Equipment

Typical Applications



The Parker Filtration ABL-1 and ABL-2 Series Air Filters.

- Saw mills
- Agricultural machines
- Articulated dump trucks
- Forestry equipment
- Wheeled loaders
- Lubricating systems
- Excavators
- Industrial power units
- Mobile cranes

Technical Data

Assembly:

Tank top mounted.

Connections:

Threads G1 $\frac{1}{4}$ (ISO 228), 1 $\frac{1}{2}$ " (UN-16-2B).

Seal material:

Seals integrated in LEIF[®] element.

Operating temperature range:

-20° to +80°C.

Filtration media:

3 micron abs (Beta value= $\beta_{75} \geq 3$ in air).

Flow fatigue characteristics:

Filter media is supported so that the optimal fatigue life is achieved.

Vacuum indicator:

ABL-1 on request only, ABL-2 0.04 bar. Visual with latch out memory.

Breather housing:

High impact strength composite.

Filter element:

LEIF[®] element.

Options:

- Adaptor with filter connection.
- Single adaptor.
- Breather with integrated pressure relieve valve for pressurised tank on request only.

LEIF[®] elements can be used for hydraulic fluids and HEES type fluids only. For other fluids contact Parker Filtration.

Pressure Drop Curves

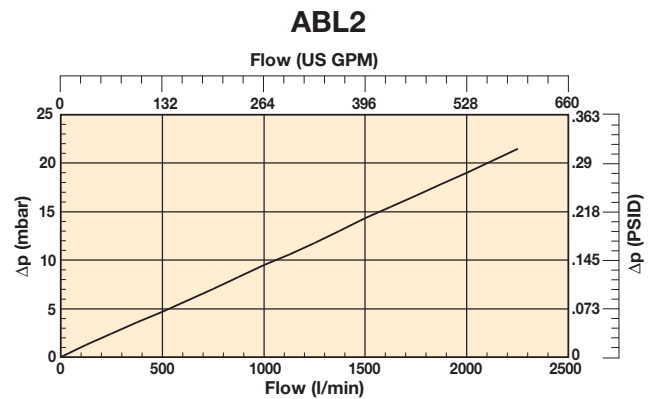
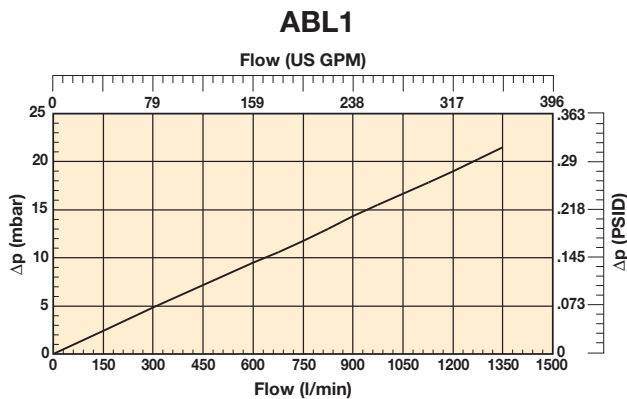

ABL Series

Reservoir Equipment

Specification

ABL-1

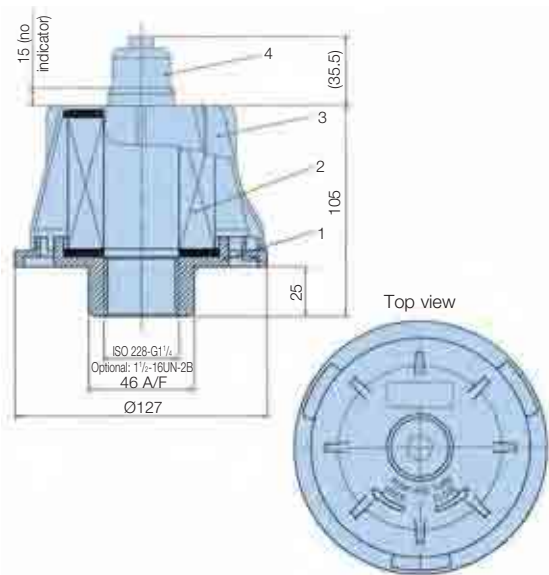

ABL-2

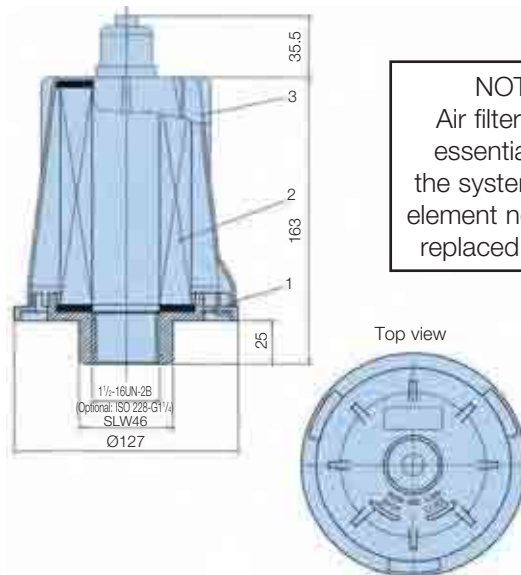

NOTICE!
Air filters are an essential part of the system and the element needs to be replaced regularly.

Extensions and filling mounting adaptors

Adaptor single

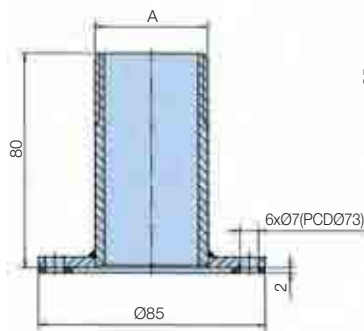

Adaptor with filler connection

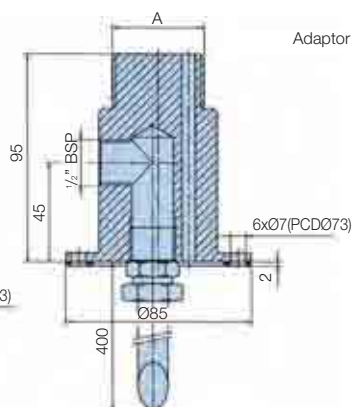

Ordering Information

Standard products table

Part number	Supersedes	Replacement elements
ABL1G114QXWL3	ABL1-G1 ¹ / ₄ -QXWL-3	QXWL3
ABL2G114QXWL13V	ABL2-G1 ¹ / ₄ -QXWL-1-3-V	QXWL13
ABL2U112QXWL13V	ABL2-U1 ¹ / ₂ -QXWL-1-3-V	QXWL13
ADAPTORABL14FP	ADAPTOR-ABL-G1 ¹ / ₄ -FP	-

Product configurator – Air Beather

Product number		Mounting options		Filtration (3µm)		Indicators		Options	
ABL1	1000 l/min	G114	ISO 228 - G1 ¹ / ₄ (BSP)	QXWL3	ABL1 Only		None		None
ABL2	2000 l/min	U112	1 ¹ / ₂ UN-16-2B	QXWL13	ABL2 Only	V	Visual	SNG	Single adaptor
								FP	Adaptor With Filler Connection

Product configurator – Adaptor

Product number	Mounting options		Options	
Adaptor ABL	G114	ISO 228 - G1 ¹ / ₄ (BSP)	SNG	Single Adaptor
	U112	1 ¹ / ₂ UN-16-2B	FP	Adaptor With Filler Connection

Replacement elements

Part number	Supersedes	Description
QXWL3	QXWL-3	3µ
QXWL13	QXWL1-3	3µ

Note 1: Part numbers featured with bold highlighted codes will ensure a 'standard' product selection.

Note 2: Alternate displayed part number selection will require you to contact Parker Filtration for availability.

Triceptor

Desiccant Type Breather



Keeping water and dust out of the reservoir

A disposable air breather solution

Triceptor desiccant type breathers are easy to fit and disposable as soon as the silica gel inside turns to pink. Triceptor breathers have three main functions; besides the removal of small solid contamination they absorb water due to the high performance silica gel desiccant. The third function is to reduce oil mist leaving the reservoir and going into the atmosphere.



Contact Information:

Parker Hannifin
Hydraulic Filter Division Europe

**European Product
Information Centre**
Freephone: 00800 27 27 5374
(from AT, BE, CH, CZ, DE, EE, ES,
FI, FR, IE, IT, PT, SE, SK, UK)
filtrationinfo@parker.com

www.parkerhfde.com

Product Features:

- Triceptor desiccant type breathers remove contamination, absorb water in the fluid and reduce oil mist leaving the reservoir into the atmosphere.
- Triceptor breathers are easy to fit and disposable when the silica gel turns to pink.
- Cost effective Triceptor breathers are suitable for a wide range of mobile and industrial applications.

Breathers Desiccant Type

Reservoir Equipment

Specification

Materials:

Casing: Clarified copolymer polypropylene.

Cap: Copolymer polypropylene.

Stand pipe: PVC.

Filtration Element: Polyester, silica gel.

Operating Temperatures: -29°C (- 20°F) to 121°C (250°F).

Seals: None.

Maximum Allowable Operating Pressure (MAOP): .34 bar (5 psi).

Particle Removal Efficiency:

98.7% (beta 75) @ 3 micron

99.5% (beta 200) @ 4 micron

99.9% (beta 1000) @ 5.3 micron

Weight:

934330T .57 kg (1.25 lbs.) each.

934331T .79 kg (1.75 lbs.) each.

934332T 1.02 kg (2.25 lbs.) each.

Features

Foam Pads

Isolates the removal materials from contact with heavy reservoir mist and securely holds materials in place.

Filter Pads

Specially designed filter pads remove solid particulate on upstream side and then regenerate by releasing those particles when air flow reverses direction. Lower pad removes airborne contamination and second pad protects against any migration of desiccant.

Air Intakes

A total of eight air intakes may be exposed to allow air to freely flow in and out of the Triceptor.

Silica Gel Desiccant

Has the highest removal capability by volume of any adsorption method. Indicates condition by changing color.

Foam pad

Insures filter pad is properly positioned and protects it from external damage.

Molded Housing

Durable shock absorbing casing provides reliable service and simple press in mounting.

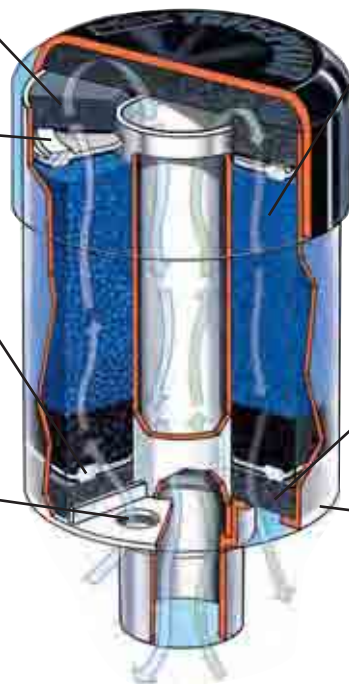

Triceptor

Desiccant Type Breather

Installation

Triceptor breathers are designed for simple installation on most equipment, regardless of mounting connection. Since TriCeptor breathers are disposable, the threaded connection allows for quick and easy maintenance. Several mounting adapters (shown below) are available to provide the desired mounting. The installation/replacement process consists of four easy steps:

1. Remove from protective plastic wrap.
2. Remove 25mm blue cap from standpipe.
3. Remove foil label to expose the necessary amount of air intake holes.
4. Twist Triceptor into mounting adapter.

Servicing the Triceptor breather is also very easy. When the silica gel changes colour from blue to a pink, the breather is no longer active and needs to be replaced. Simply remove the unit and discard properly.

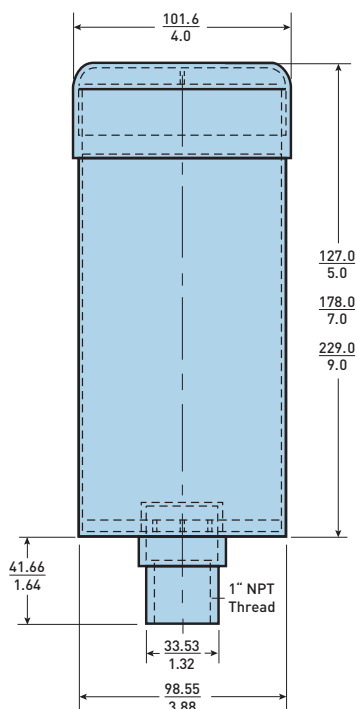

Note: Triceptor breathers comply with European REACH regulations

$$\text{Linear Measurement} = \frac{\text{mm}}{\text{in}}$$

Air Flow Performance

The curves below show the air flow performance of the three Triceptor breathers. To insure the longest life possible, the initial clean pressure drop should not exceed 0.103 bar.

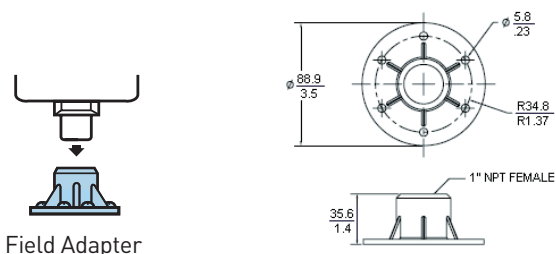
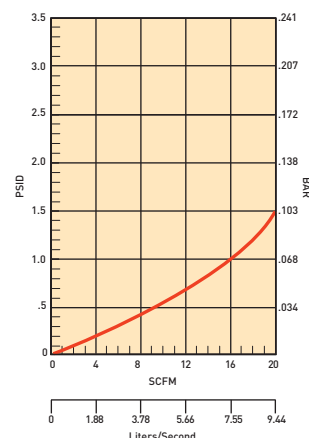
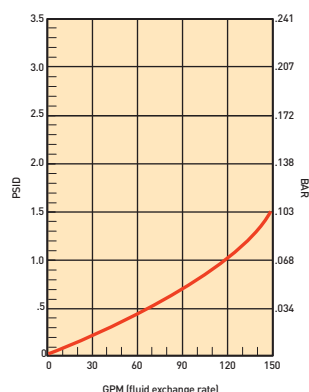

Field Adapter

Model	Part Number	Quantity
127mm Breather	934330T	6 pcs.
178mm Breather	934331T	6 pcs.
229mm Breather	934332T	6 pcs.
Field Adapter Nylon	937546	1 pc.

Glass-Filled Nylon and Metal Breathers

IP65 Rated, Metal, Screw-on and Lockables Reservoir Equipment



Compact and lightweight reservoir solutions

IP65 Co-polymer breathers and metal breathers

The IP65 rated range of moulded, non-corrodible, glass-filled nylon air breathers combine strength with a lightweight design. Single hole, 6-hole, 3-hole and screw-on options are available; plus metal air breather, filler breather and lockable options are a proven range of quality reservoir solutions.



Contact Information:

Parker Hannifin
Hydraulic Filter Division Europe

European Product
Information Centre
Freephone: 00800 27 27 5374
(from AT, BE, CH, CZ, DE, EE, ES,
FI, FR, IE, IT, PT, SE, SK, UK)
filtrationinfo@parker.com

www.parkerhfde.com

Product Features:

- Moulded in non-corrodible, glass-filled nylon – strong and light.
- Single hole, 6 hole and 3 hole installation.
- Screw-on breather range – G $\frac{1}{2}$ and G $\frac{3}{4}$ options.
- Compact range – G $\frac{1}{4}$, G $\frac{3}{8}$, R $\frac{1}{2}$ and R $\frac{3}{4}$ options.
- Metal filler breathers – pressurized threaded type.
- Metal filler breathers – unpressurized threaded type.
- Filter flange type.
- Lockable range for reservoir security and oil protection.

IP65 Rated Filler Breathers

Reservoir Equipment

Specification for Single and 6 Hole Installation



Option 1

Construction:
Moulded in non-corrodible glass-filled nylon combining strength with a lightweight design.

Options:
(1) single (63mm dia) hole Filler breather installation that eliminates drilled and tapped holes using self-locking clamps.
(2) 6 hole Filler Breather Installation that uses 6 x No 10 thread forming screws.
(3) 3 hole filler breather utilises 3 x zinc and clear chromate plated steel screws.

Strainers:
Unique design diffuses oil flow into the reservoir.
(1) Single length in polypropylene (95mm length)
(2) 2-piece telescopic in polypropylene (195mm length max.)

Filtration element:
Expanded polyurethane foam, 10 micron nominal.

Seals:
Nitrile.

Working temperature:
-30°C to +90°C.

Pressurised filler breathers:
Available in 3 pressure options to maintain a positive pressure in a reservoir.

Pressurisation options:
0.2, 0.35 and 0.7 bar crack pressure.

Pressurisation valve:
Nylon/Nitrile.

Dipstick:
Available for use with options 1 and 2. Dipsticks are available in 2 lengths and in packs of 10.

Dipstick material:
ABS.

Hi/Lo indicators:
Acetal. Adjustable Red/Green level indicators.

Dipstick lengths:
200mm and 400mm.

Breather weight:
0.2Kg.

Anti-splash feature:
The unique design anti-splash feature is standard on all options 1 and 2 and allows for a dipstick to be fitted if required.

Option 1 Filler Breathers (Single Hole Installation)

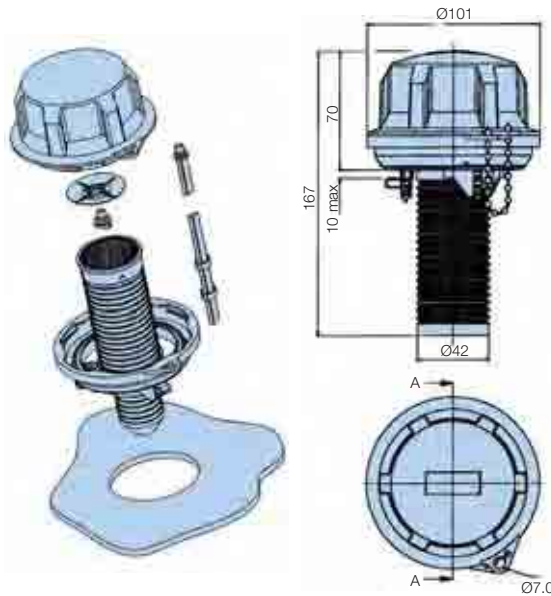

Option 1. Single Hole Filler Breathers – Pressurised

Part number	Supersedes	Description 10µ abs.
AB98212011	AB.98212011.UC	Pressurised 0.2bar with 95mm strainer
AB98213011	AB.98213011.UC	Pressurised 0.35bar with 95mm strainer
AB98212001	AB.98212001.UC	Pressurised 0.2bar without strainer
AB98212021	AB.98212021.UC	Pressurised 0.2bar with telescopic strainer
AB98213001	AB.98213001.UC	Pressurised 0.35bar without strainer
AB98213021	AB.98213021.UC	Pressurised 0.35bar with telescopic strainer
AB98217001	AB.98217001.UC	Pressurised 0.7bar without strainer
AB98217011	AB.98217011.UC	Pressurised 0.7bar with 95mm strainer
AB98217021	AB.98217021.UC	Pressurised 0.7bar with telescopic strainer

Note 1: Part numbers featured with bold highlighted codes will ensure a 'standard' product selection.

Note 2: Alternate displayed part number selection will require you to contact Parker Filtration for availability.

AB98XXX Pressurised Pressure Drop Curves

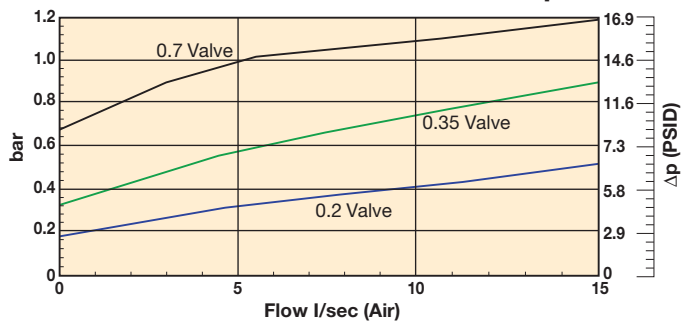

AB98XXX Non-Pressurised Pressure Drop Curves

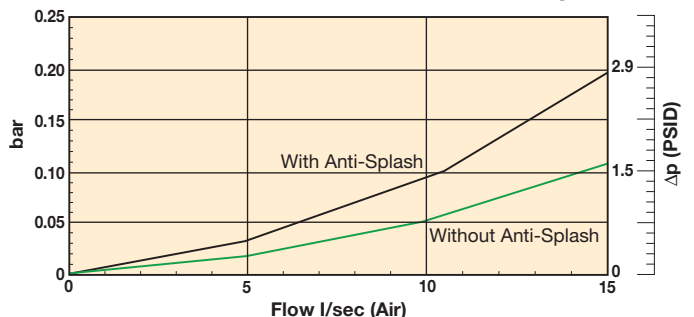

Option 1. Single Hole Filler Breathers – Non-Pressurised

Part number	Supersedes	Description 10µ abs.
AB98210011	AB.98210011.UC	Filler breather with 95mm strainer
AB98210021	AB.98210021.UC	Filler breather with telescopic strainer
AB98210001	AB.98210001.UC	Filler breather without strainer

Note 1: Part numbers featured with bold highlighted codes will ensure a 'standard' product selection.

Note 2: Alternate displayed part number selection will require you to contact Parker Filtration for availability.

Filler Breathers (6 Hole Installation)

Option 2

Note 1. Un-pressurised 6 hole fixing:

Form 6 off tank mounting holes between $\varnothing 4.0$ and 4.4mm (dependent on the material and thickness – see guide below) equispaced on $70\text{-}73\text{mm}$ P.C.D. to suit supplied No.10 thread forming screws.

Note 2. Pressurised 6-hole fixing:

Form 6 off tank mounting holes between $\varnothing 4.0$ and $\varnothing 4.4\text{mm}$ (dependent on the material and thickness – see guide below) equispaced on 73mm P.C.D. to suit supplied No.10 thread forming screws.

Note 3. Reservoir mounting guide

Sheet thickness mm	Hole size mm
1.2	4.0
2.0	4.10
3.15	4.30
4.0	4.30
5.0	4.40

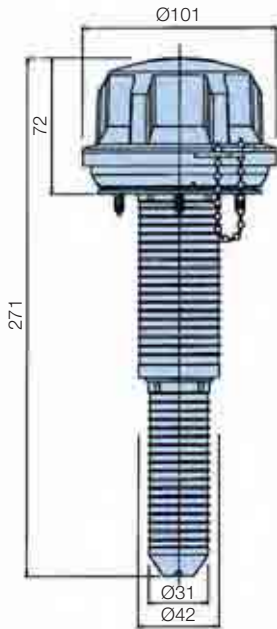

Telescopic Strainer

The telescopic strainer design is ideal, where reservoir depth allows, to increase the surface area of the strainer, improving still further its straining ability, oil flow-through and allowing for longer dipstick lengths.

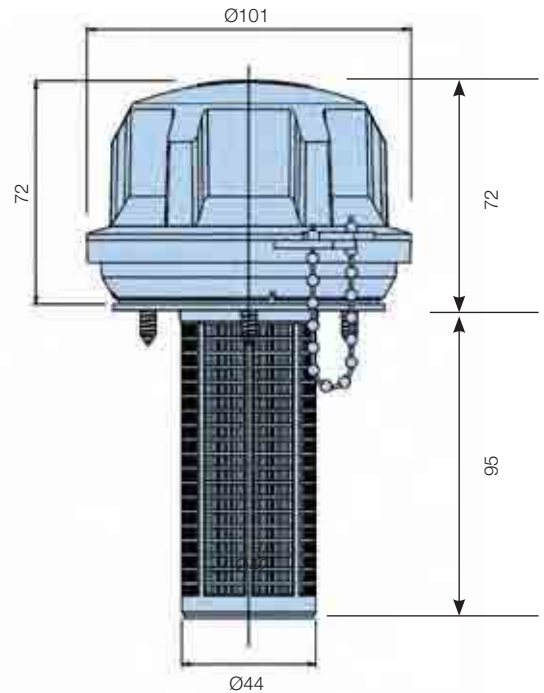

Option 2. 6 Hole Filler Breathers – Pressurised

Part number	Supersedes	Description 10 μ abs
AB98817011	AB.98817011.UC	Pressurised 0.7bar with 95mm strainer
AB98812001	AB.98812001.UC	Pressurised 0.2bar without strainer
AB98812011	AB.98812011.UC	Pressurised 0.2bar with 95mm strainer
AB98812021	AB.98812021.UC	Pressurised 0.2bar with telescopic strainer
AB98813001	AB.98813001.UC	Pressurised 0.35bar without strainer
AB98813011	AB.98813011.UC	Pressurised 0.35bar with 95mm strainer
AB98813021	AB.98813021.UC	Pressurised 0.35bar with telescopic strainer
AB98817001	AB.98817001.UC	Pressurised 0.7bar without strainer
AB98817021	AB.98817021.UC	Pressurised 0.7bar with telescopic strainer

Note 1: Part numbers featured with bold highlighted codes will ensure a 'standard' product selection.

Note 2: Alternate displayed part number selection will require you to contact Parker Filtration for availability.

Option 2. 6 Hole Filler Breathers – Non-Pressurised

Part number	Supersedes	Description 10 μ abs
AB98810001	AB.98810001.UC	Filler breather without strainer
AB98810011	AB.98810011.UC	Filler breather with 95mm strainer
AB98810021	AB.98810021.UC	Filler breather with telescopic strainer

Note 1: Part numbers featured with bold highlighted codes will ensure a 'standard' product selection.

Note 2: Alternate displayed part number selection will require you to contact Parker Filtration for availability.

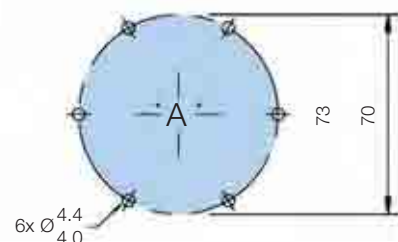

Filler Breathers

Reservoir Equipment

Option 3 Filler Breathers (3 Hole Installation)



New Options Fully Tested

As part of the design development programme for the new IP65 Filler Breathers, extensive performance and endurance testing was carried out to ensure durability and efficiency.

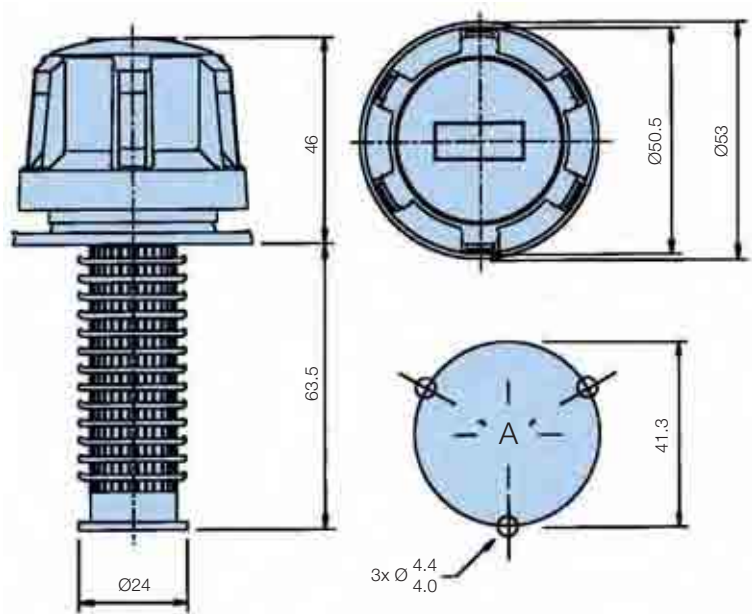

3-hole Filler Breathers (6-hole available)

Part number	Description 10µ abs
AB68110	Filler breather without strainer
AB68118	Filler breather with 95mm strainer

Note 1: Part numbers featured with bold highlighted codes will ensure a 'standard' product selection.

Note 2: Alternate displayed part number selection will require you to contact Parker Filtration for availability.

Note 3: Not suitable for use with B.68206/207

Note 4: 6-hole AB.68910/AB.68918 option available.

Note: Form 3 off tank mounting holes between Ø4.0 and Ø4.4mm (dependent on the material and thickness – see chart for guide) equispaced on 41.3 P.C.D. to suit No. 10 thread forming screws supplied.

Dipstick Options

Dipstick Ordering

Part number	Supersedes	Description
B68206	DIP.206	10 x 200mm Dipsticks
B68207	DIP.207	10 x 400mm Dipsticks

Note 1: Part numbers featured with bold highlighted codes will ensure a 'standard' product selection.

Note 2: Alternate displayed part number selection will require you to contact Parker Filtration for availability.

Dipsticks

The dipstick, available in 2 lengths – 200mm and 400mm, can be cut to the required length or left as it is and the Hi/Lo indicators moved and positioned on the dipstick itself by squeezing the sides of the indicator and repositioning along the dipstick.



Screw-On Type Air Breathers

Reservoir Equipment

Standard Screw-On Breathers - Specification



Option 1- G^{1/2} and G^{3/4} (Ø101)

Construction:

Moulded in non-corrodible glass-filled nylon combining strength with a lightweight design.

Option 1:

2 screw on type air breathers are available – G^{1/2} or G^{3/4} threaded base models.

Filtration element:

Expanded polyurethane foam, 10 micron absolute.

Seals:

Nitrile.

Working temperature:

-30°C to +90°C.

Pressurised air breathers:

Available in 3 pressure options to maintain a positive pressure in a reservoir.

Pressurisation options:

0.2, 0.35 and 0.7 bar crack pressure.

Pressurisation valve:

Nylon/Nitrile.

Dipstick:

Available for use with all options. Dipsticks are available in 2 lengths and in packs of 10.

Dipstick material:

ABS.

Hi/Lo indicators:

Acetal. Adjustable red/green level indicators.

Dipstick lengths:

200mm and 400mm.

Breather weight:

0.2Kg.

Anti-splash feature:

The unique design anti-splash feature is standard on option 1 and allows for a dipstick to be fitted if required.

Pressure Drop Flow Curve

AB98XXX Screw-on Non-Pressurised Pressure Drop Curves

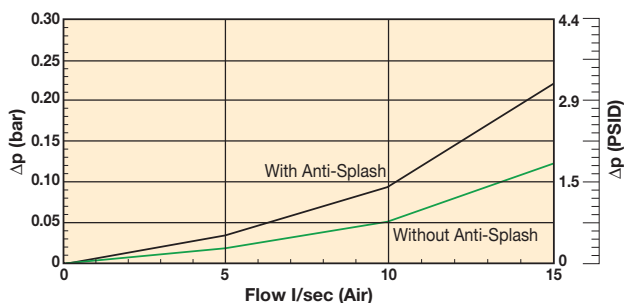

Note: For pressure drop information on the Option 1. Pressurised consult Parker Filtration.

Option 1 – G^{1/2} or G^{3/4}

Part number	Supersedes	Description 10µ nom
AB98610101	AB.98610101.UC	G ^{1/2} Un-pressurised
AB98612101	AB.98612101.UC	G ^{1/2} pressurised 0.2 bar
AB98613101	AB.98613101.UC	G ^{1/2} pressurised 0.35 bar
AB98617101	AB.98617101.UC	G ^{1/2} pressurised 0.7 bar
AB98410101	AB.98410101.UC	G ^{3/4} Un-pressurised
AB98412101	AB.98412101.UC	G ^{3/4} pressurised 0.2 bar
AB98413101	AB.98413101.UC	G ^{3/4} pressurised 0.35 bar
AB98417101	AB.98417101.UC	G ^{3/4} pressurised 0.7 bar

Note 1: Part numbers featured with bold highlighted codes will ensure a 'standard' product selection.

Note 2: Alternate displayed part number selection will require you to contact Parker Filtration for availability.

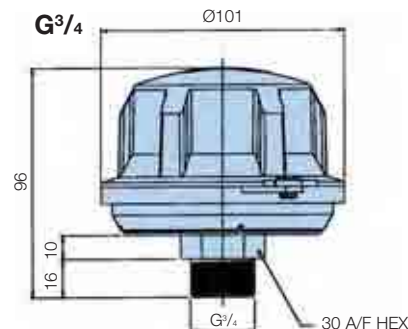
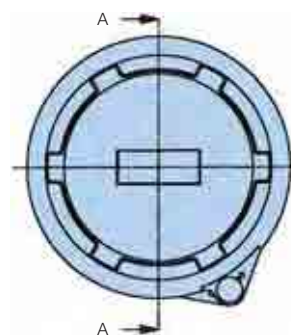
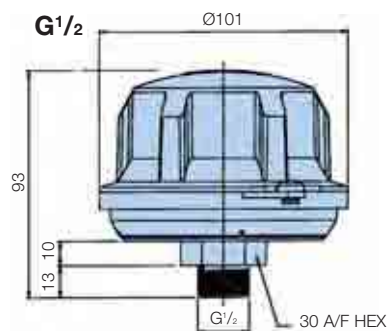

Screw-On Type Air Breathers

Reservoir Equipment

Compact Screw-On Breathers - Specification

Option 2 – G^{1/4}, G^{3/8}, R^{1/2} and R^{3/4} (Ø40)

Construction:

G^{1/4}, G^{3/8}, R^{1/2} and R^{3/4} cap and base plate mouldings in nylon 66.

Element:

Expanded Polyurethane foam, 10 micron absolute.

Dipstick:

Available for use with R^{1/2} and R^{3/4}.

Dipstick material:

ABS.

Hi/Lo indicators:

Acetal adjustable red/green level indicators.

Dipstick lengths:

200mm and 400mm (packs of 10).

Breather weights:

0.028Kg

Pressure Drop Flow Curve

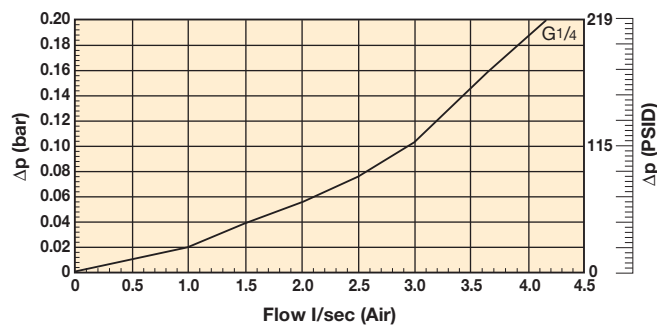

Note: For pressure drop information on G^{3/8}, R^{1/2} and R^{3/4}, consult Parker Filtration.

Ordering Information

Option 2 – G^{1/4}, G^{3/8}, R^{1/2} and R^{3/4} (Packs of 10 only)

Part number	Supersedes	Description 10µ abs
AB683101	AB.683101.UC	G ^{1/4} Un-pressurised
AB68X101	AB.68X101.UC	G ^{3/8} Un-pressurised
AB68Y101	AB.68Y101.UC	R ^{1/2} Un-pressurised
AB68Z101	AB.68Z101.UC	R ^{3/4} Un-pressurised

Note 1: Part numbers featured with bold highlighted codes will ensure a 'standard' product selection.

Note 2: Alternate displayed part number selection will require you to contact Parker Filtration for availability.

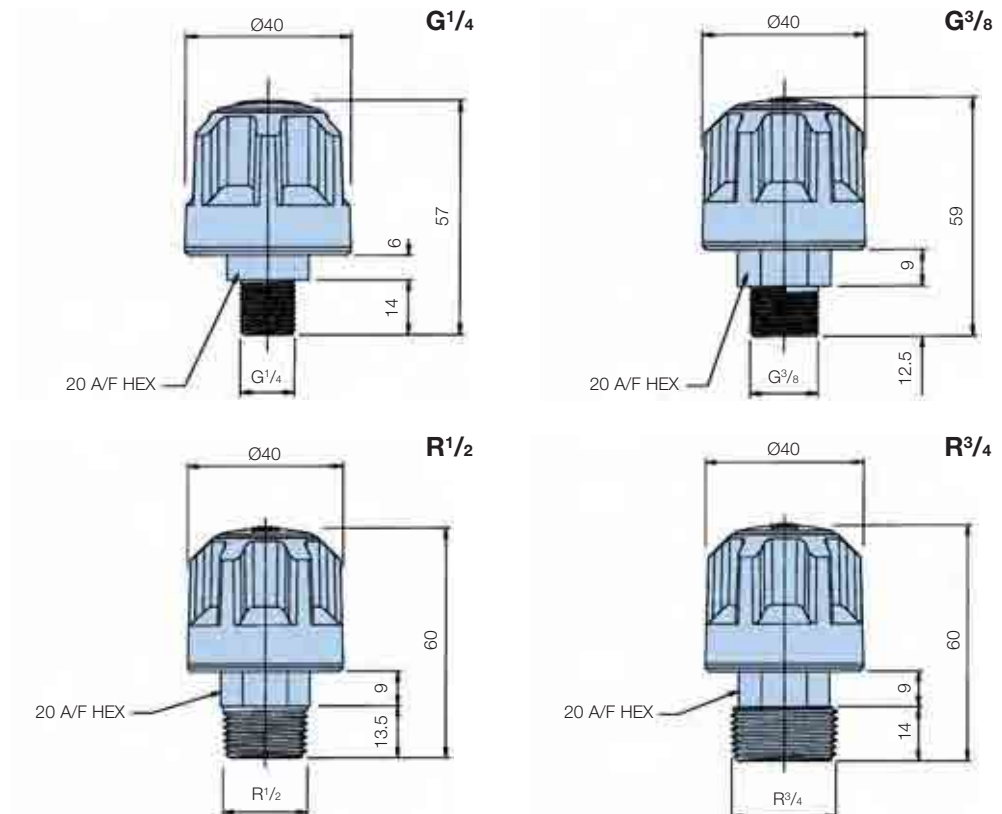

Screw-On Type Air Breathers - Specification

Option 3 – G³/₈, G¹/₂ and G³/₄ (Ø70)

Construction:

Mouldings in glass-filled nylon and glass coupled polypropylene.

Element:

Expanded Polyurethane foam, 10 micron absolute.

Seals:

Nitrile.

Pressurised air breathers:

Available G³/₈, G¹/₂ and G³/₄,
3 pressure options to maintain a positive pressure in a reservoir.

Pressurisation options:

0.2, 0.35 and 0.7 bar crack pressure.

Pressurisation valve:

Nylon.

Dipstick:

Available for use with G³/₈, G¹/₂ and G³/₄.

Dipstick material:

Mini-series in brass.

Hi/Lo indicators:

Acetal adjustable red/green level indicators.

Dipstick lengths:

200mm and 400mm (packs of 10).

Breather weights:

0.075Kg, Mini-series – 0.019Kg.

Pressure Drop Flow Curve

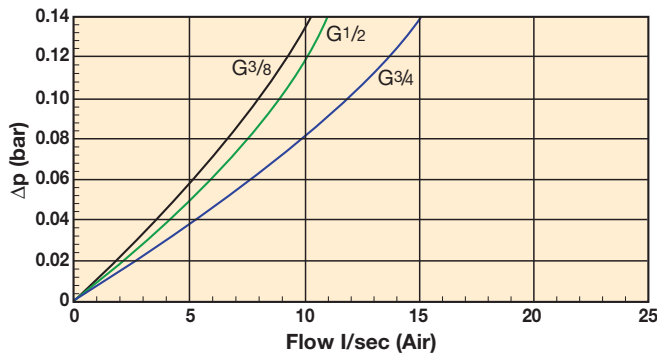

Ordering Information

Option 3 – G³/₈, G¹/₂ and G³/₄

Part number	Supersedes	Description 10µ abs
AB685101	SAB.5101	G ³ / ₈ Un-pressurised
AB687101	SAB.7101	G ¹ / ₂ Un-pressurised
AB686101	SAB.6101	G ³ / ₄ Un-pressurised

Note 1: Part numbers featured with bold highlighted codes will ensure a 'standard' product selection.

Note 2: Alternate displayed part number selection will require you to contact Parker Filtration for availability.

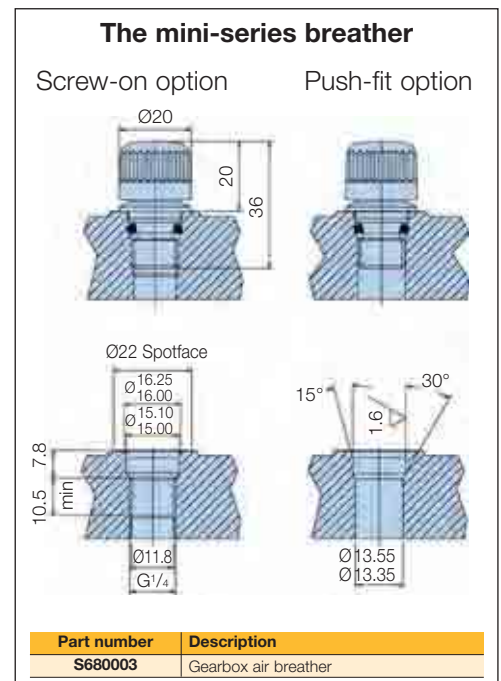
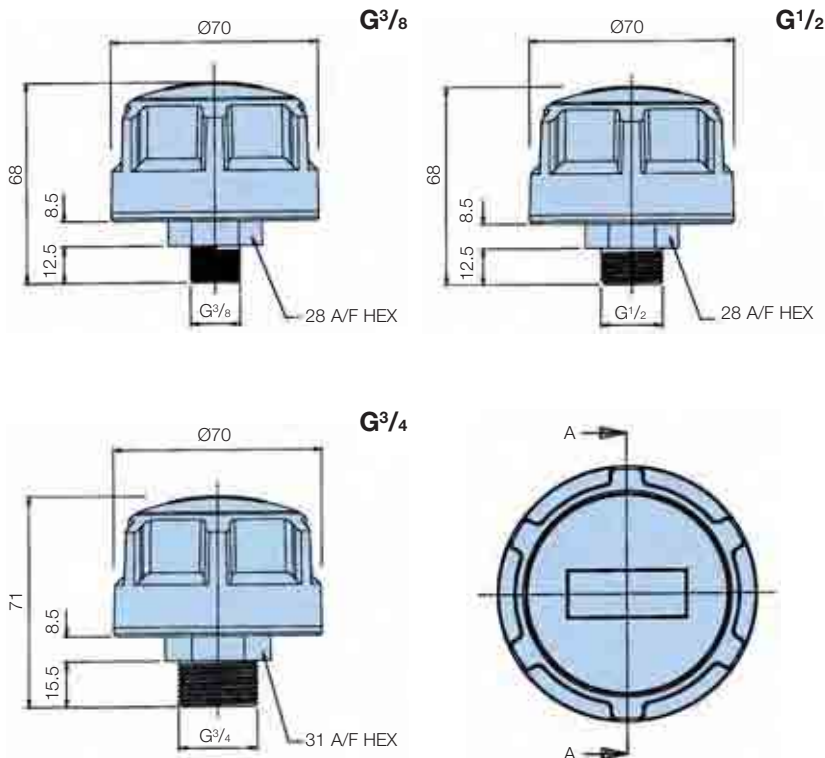

Filler Breathers (Metal)

Reservoir Equipment

Metal Airbreather/Filler breather Specification

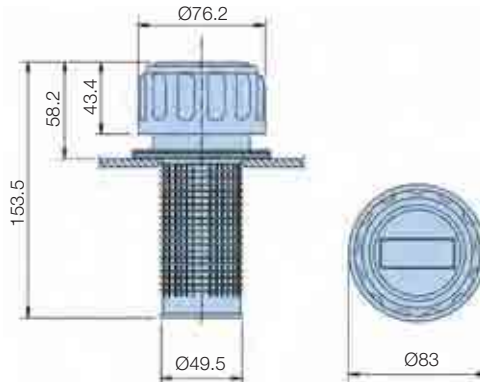

Locking lug option (5561)

For added security, certain Parker Filtration Metal Filler Breather Filters can be specified with a locking lug option.



Note: Dimensions relate to 1163 and 1730 options.
Note: Max. operating temperature = +90°C.

Ordering Information

Standard products table

Part number	Supersedes	Replacement cap	Supersedes	Displacement l/min	Crack pressure	Micron rating	Air flow m³/min	Thread	Weight
Threaded airbreather (unpressurised)									
SAB156210	SAB.1562.10	N/A	N/A	430	N/A	10µ abs	0.45	G ³ / ₄	0.20kg
SAB156310	SAB.1563.10	N/A	N/A	135	N/A	10µ abs	0.15	G ¹ / ₄	0.06kg
Filler breather - filter flange type (unpressurised)									
AB116310	AB.1163.10	CAP.116310	CAP.1163.10	430	N/A	10µ abs	0.45	N/A	0.24kg
AB138010	AB.1380.10	CAP.138010	CAP.1380.10	135	N/A	10µ abs	0.15	N/A	0.08kg
5561	N/A	N/A	N/A	430	N/A	10µ abs	0.45	N/A	0.24kg
Filler breather - filter flange type (pressurised)									
PAB1730105	PAB.1730.10.5	CAP.1730105	CAP.1730.10.5	430	0.35 bar	10µ abs	0.45	N/A	0.27kg
PAB17301010	PAB.1730.10.10	CAP.17301010	CAP.1730.10.10	430	0.70 bar	10µ abs	0.45	N/A	0.27kg
Air breather - threaded type (pressurised)									
SPA1731105	SPA.1731.10.5	N/A	N/A	430	0.35 bar	10µ abs	0.45	G ³ / ₄	0.20kg
SPA17311010	SPA.1731.10.10	N/A	N/A	430	0.70 bar	10µ abs	0.45	G ³ / ₄	0.20kg

Note 1: Part numbers featured with bold highlighted codes will ensure a 'standard' product selection.

Note 2: Alternate displayed part number selection will require you to contact Parker Filtration for availability.

1731 - (Pressurised) - 1562 (Un-pressurised) - Threaded type

Displacement:

430 l/min.

Micron rating:

10µ abs

Air flow:

0.45m³/min.

Weight:

0.2 Kg.

Thread:

G³/₄.

Valve crack-pressure 1731:

0.35 and
0.7 bar.

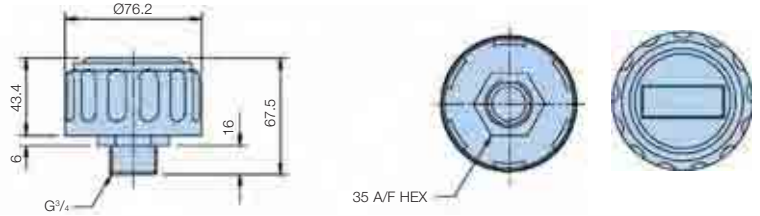

1563 - Threaded type (Un-pressurised)

Displacement:

1562 = 430 l/min.

1563 = 135 l/min.

Micron rating:

10µ abs

Air flow:

1562 = 0.45m³/min.

1563 = 0.15m³/min.

Weight:

1562 = 0.20 Kg.

1563 = 0.06 Kg.

Thread:

1562 = G³/₄.

1563 = G¹/₄.

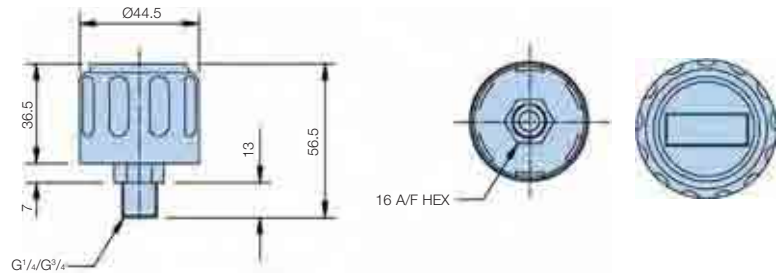

1380 - Filter flange type

Displacement:

135 l/min.

Micron rating:

10µ abs

Air flow:

0.15m³/min.

Weight:

0.08 Kg.

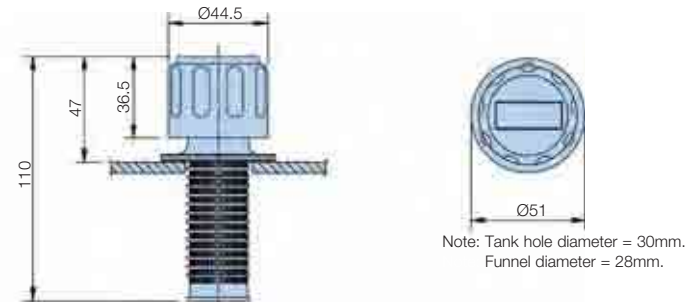

Tank installation notes

1. Un-pressurised 6 hole fixing (Type 1163)

Form off tank mounting holes between Ø4.0 and Ø4.4 (dependant on the material and thickness, consult Parker Filtration) equispaced on 70.0-73.0 P.C.D. to suit
No. 10 thread forming screws supplied.

2. Pressurised 6 hole fixing (Type 1730)

Form 6 off mounting holes between Ø4.0 and Ø4.4 equispaced on 73.0 P.C.D. to suit
No. 10 thread forming screws supplied.

3. Un-pressurised 3 hole fixing (Type 1380)

Form 3 off tank mounting holes between Ø5.25 – 5.35 mm equispaced on 41.3 P.C.D. to suit
No. 10 thread forming screws supplied.

Breather Units

Small Breather Specification

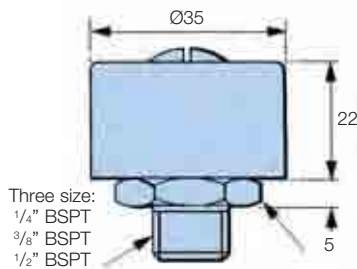

Ordering Information

Part number	Supersedes	Description
H00279001	H00279-001	Small breather 1/4 BSPT thread
H00279002	H00279-002	Small breather 3/8 BSPT thread
H00279003	H00279-003	Small breather 1/2 BSPT thread

Lockable Filler Breather

Reservoir Equipment

Installation Details



Tank Mounting

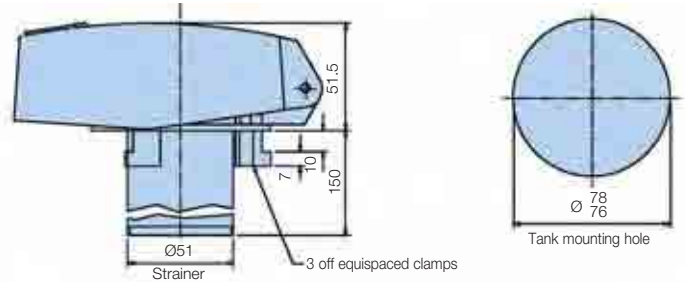

Stand Pipe Mounting

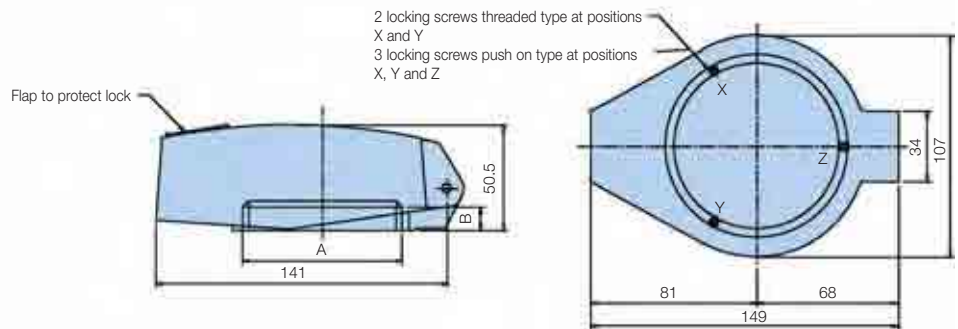

Lockable Filler Breather Selection

Total assembly pressure drop flow curve – 10µ elements

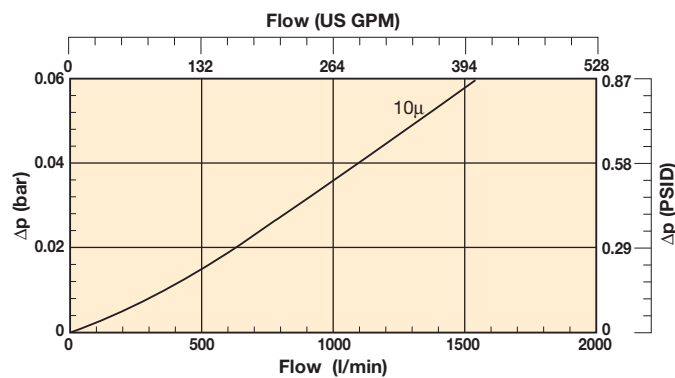

Ordering Information

Part number	Description
LFC622142	Non-breathing (No element) Clamp mounting with strainer
LFC622212	10µ nom element, G2 thread with strainer
LFC622242	10µ nom element, clamp mounting with strainer
LFC622432	10µ nom vented (air in) push on mounting with strainer
LFC622122	Non-breathing (No element) 2 1/2" BSP thread with strainer
LFC622222	10µ nom element, G2 1/2 thread with strainer
LFC622411	10µ nom vented (air in) G2 thread without strainer

Note 1: Part numbers featured with bold highlighted codes will ensure a 'standard' product selection.

Note 2: Alternate displayed part number selection will require you to contact Parker Filtration for availability.



Spin-On Air Breathers

Reservoir Equipment



High capacity air breathers

Ideal for high flow heavy contamination systems

Spin-on air filters for tank mounted breathing solutions offer high capacity, disposable air breathers to remove airborne contamination. 2 x 5 micron models are available – 700 l/min and 1500 l/min ideal for high flow heavy contamination systems.



Contact Information:

Parker Hannifin
Hydraulic Filter Division Europe

**European Product
Information Centre**
Freephone: 00800 27 27 5374
(from AT, BE, CH, CZ, DE, EE, ES,
FI, FR, IE, IT, PT, SE, SK, UK)
filtrationinfo@parker.com

www.parkerhfde.com

Product Features:

- High capacity air breathers to remove airborne contamination.
- Disposable, 5 micron nominal quality elements.
- Models – 700, 1500, 1700 and 3000 l/min.
- Ideal for high flow heavy contamination systems.

Spin-On Air Breathers

Reservoir Equipment

Specification



- High capacity air breathers designed for the removal of airborne contamination in hydraulic systems to support environmental maintenance.
- Ideal for high flow systems and heavily contaminated environments.
- Disposable spin-on elements quickly and easily replaced.
- 5 micron nominal quality filtration elements.
- 2 models available – 700 l/min and 1500 l/min.
- Available with a pressurised valve in the mounting adaptor.

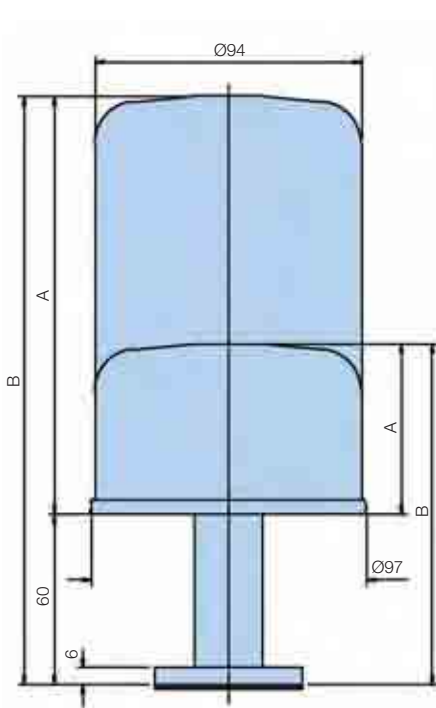

Standard spin-on air breather stem

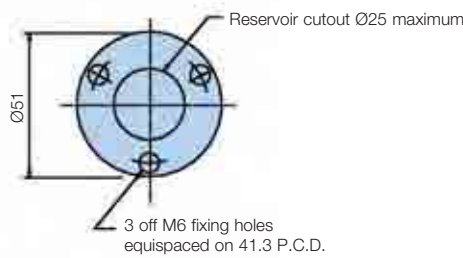

Pressurised spin-on air breather stem

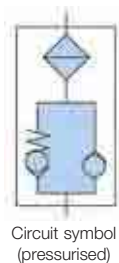
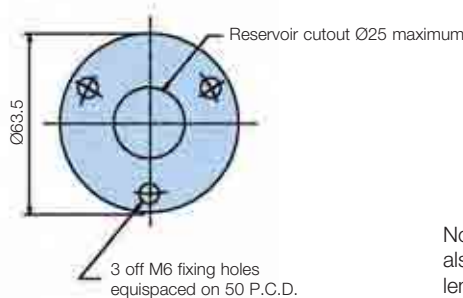

Note: Spin-on air breather elements can also be mounted directly on to any suitable length of 3/4" BSP threaded pipe.

Ordering Information

5µ Spin-on air breathers

Part number	Supersedes	Air flow	Valve crack pressure	A mm	B mm	Weight	Replacement element
S340056	N/A	700 l/min	Unpressurised	60	120	0.6Kg	4930
S340052	N/A	1500 l/min	Unpressurised	148	208	0.75Kg	588410
S340058	*S.340058	700 l/min	0.35 Bar	60	120	0.69Kg	4930
S340059	**S.340059	700 l/min	0.70 Bar	60	120	0.69Kg	4930
S340054	*S.340054	1500 l/min	0.35 Bar	148	208	0.8Kg	588410
S340055	**S.340055	1500 l/min	0.70 Bar	148	208	0.8Kg	588410

Note 1: Part numbers featured with bold highlighted codes will ensure a 'standard' product selection.

Note 2: Alternate displayed part number selection will require you to contact Parker Filtration for availability.

Note 3: Reservoir must be capable of withstanding pressurisation.



Mounting face for standard and large breather

- High capacity air breathers and filler/breathers designed for the removal of airborne contamination in hydraulic systems to support environmental maintenance.
- Ideal for high flow systems and heavily contaminated environments.
- Disposable spin-on elements quickly and easily replaced.
- 3 micron absolute quality filtration elements.
- Models available – 1700 l/min and 3000 l/min.

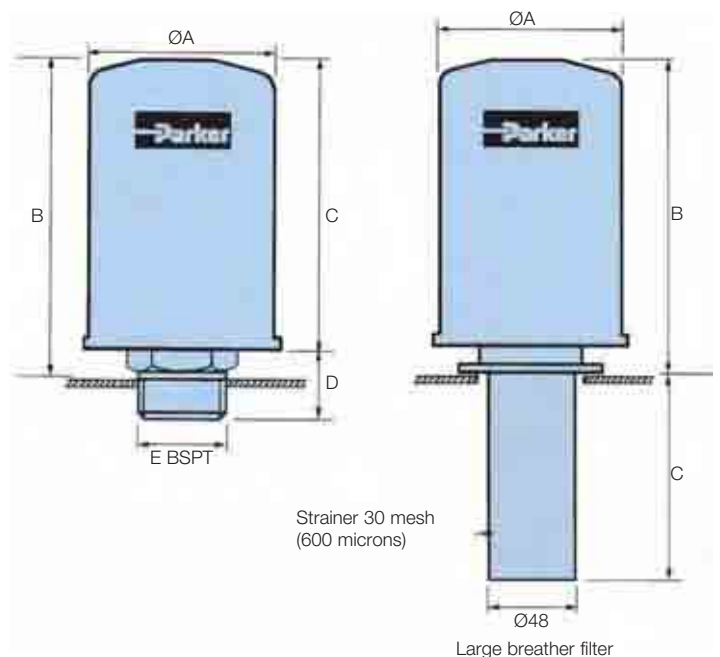
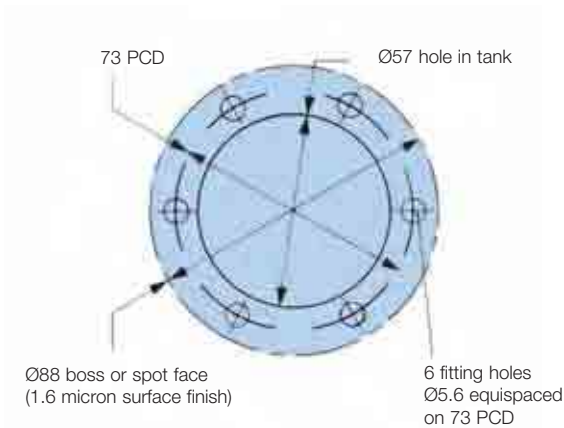

Specification

Maximum operating temperature:

-20°C to +90°C.

Construction materials:

Epoxy coated steel components to resist corrosion. resistant paint finish on large breathers.

Fluid compatibility:

Suitable for use with mineral oils and water oil emulsions.

Weights:

Large: H00834001 1.0 Kg
 H00834002 1.65 Kg
 H00834003 1.90 Kg

Each breather filler is supplied with mounting gaskets and self-tapping screws.

Ordering Information

Large breather dimensions

Part number	Supersedes	Air flow l/min	Dimensions (mm)				Ports E
			A	B	C	D	
H00834004	H00834-004	1700	97	147	135	30	¾
H00834005	H00834-005	3000	134	198	180	36	1¼

Note 1: Part numbers featured with bold highlighted codes will ensure a 'standard' product selection.

Note 2: Alternate displayed part number selection will require you to contact Parker Filtration for availability.

Large breather filler dimensions

Part number	Supersedes	Air flow l/min	Dimensions (mm)			Replacement element complete with bayonet	Supersedes
			A	B	C		
H00834001	H00834-001	1700	97	165	114	H00834006	H00834-006
H00834002	H00834-002	3000	134	204	114	H00834007	H00834-007
H00834003	H00834-003	3000	134	204	203	H00834007	H00834-007



Fluid Level Measurement

Fluid Level/Temperature Gauges

Reservoir Equipment



A proven solution for tank oil level measurement

Universal fixing designed for front or rear tank mounting

Fluid level/temperature gauges are available in 3 sizes each with 2-hole mounting at 76mm, 127mm and 254mm mounting centres. The high-visibility viewing lens is a one-piece design for added security, moulded in shatterproof, transparent polyamide.



Contact Information:

Parker Hannifin
Hydraulic Filter Division Europe

European Product Information Centre
Freephone: 00800 27 27 5374
(from AT, BE, CH, CZ, DE, EE, ES, FI, FR, IE, IT, PT, SE, SK, UK)
filtrationinfo@parker.com

www.parkerhfde.com

Product Features:

- 3 sizes of fluid level/temperature gauge. 2 hole mounting.
- 76mm, 127mm and 254mm mounting centres.
- A one-piece design, high-visibility viewing lens for added security.
- Moulded in shatterproof, transparent polyamide.

Specification



Construction:

Lens Transparent polyamide.
 Lens base Nylon 66.
 Shroud High impact polystyrene.
 No aluminium content.

Bolts:

Steel.

Seals:

Nitrile.

Maximum working pressure:

1 bar.

Working temperature:

-30°C to +90°C.

Fluid compatibility:

Mineral and petroleum based oils.

Note:

A 50mm model with metal shroud finished in black available.

Recommended bolt tightening torque:

10 Nm maximum.

Thermometer scale range:

+30°C to +90°C.

Temperature Indicator:

Blue alcohol.

Note:

1. Locate seals in mounting recess before fitting.
2. Select the size required by studying the installation details to determine a part number.

Size 1 Installation Details

For 'through hole' mounting:

Hole size	-Thread-	
	M10	M12
Preferred	11.0	13.0
Maximum	13.0	14.0

Torque = 10Nm max

For tapped holes:

Holes to be tapped square to mounting face.
 Tolerance on hole centres: +0.5
 -0.2

For welded back nuts:

The above details should be combined.

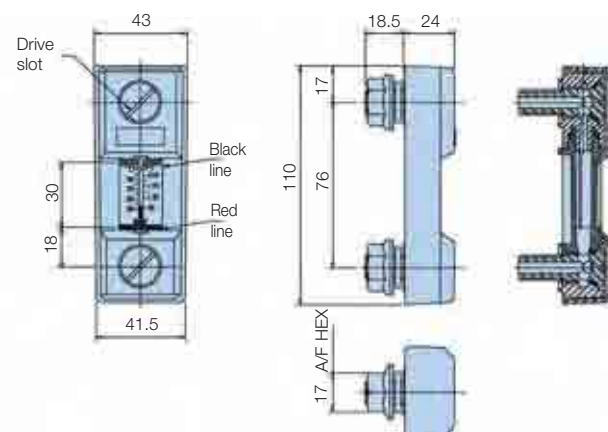

Installation and Application Information

Simple to Install

The universal fixing is designed for either front or rear fixing. Just two holes in the tank – threaded for front fixing – and the gauge is ready to install. After positioning the gauge the bolts are simply tightened to provide a secure seal. There is no fear of leakage with the square section seals and the two-point mounting system eliminates problems with tank distortion. M10 and M12 bolt thread options are available.

Easy to Read

The high-visibility lens is one-piece for added security and moulded in shatterproof, transparent polyamide for an accurate and clear oil level and temperature indication. Further gauge protection is provided by a specially designed shroud moulded in high-impact, black polystyrene.

Size 1 Ordering Information

Standard products table

Part number	Supersedes	Description	Centres	Thread	Max temp	Weight
FL69121	FLT.121	Fluid level/temp	76mm	M10	90°C	0.13Kg
FL69123	FLT.123	Fluid level/temp	76mm	M12	90°C	0.13Kg
FL69111	FL.111	Fluid level	76mm	M10	90°C	0.13Kg
FL69113	FL.113	Fluid level	76mm	M12	90°C	0.13Kg

Note 1: Part numbers featured with bold highlighted codes will ensure a 'standard' product selection.

Note 2: Alternate displayed part number selection will require you to contact Parker Filtration for availability.

Fluid Level/Temperature Gauges

Reservoir Equipment

Size 2 Installation Details

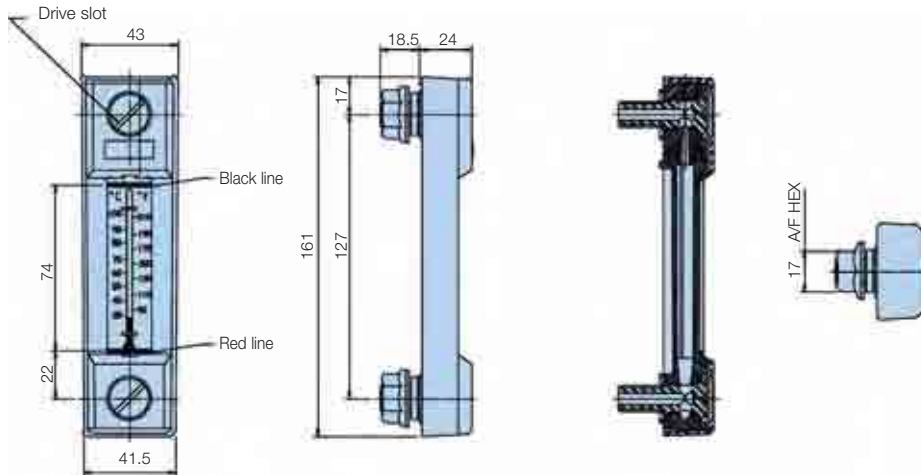

Size 2 Ordering Information

Standard products table

Part number	Supersedes	Description	Centres	Thread	Max temp	Weight
FL69221	FLT.221	Fluid level/temp	127mm	M10	90°C	0.15Kg
FL69223	FLT.223	Fluid level/temp	127mm	M12	90°C	0.15Kg
FL69211	FL.211	Fluid level	127mm	M10	90°C	0.15Kg
FL69213	FL.213	Fluid level	127mm	M12	90°C	0.15Kg

Note 1: Part numbers featured with bold highlighted codes will ensure a 'standard' product selection.

Note 2: Alternate displayed part number selection will require you to contact Parker Filtration for availability.

Size 3 Installation Details

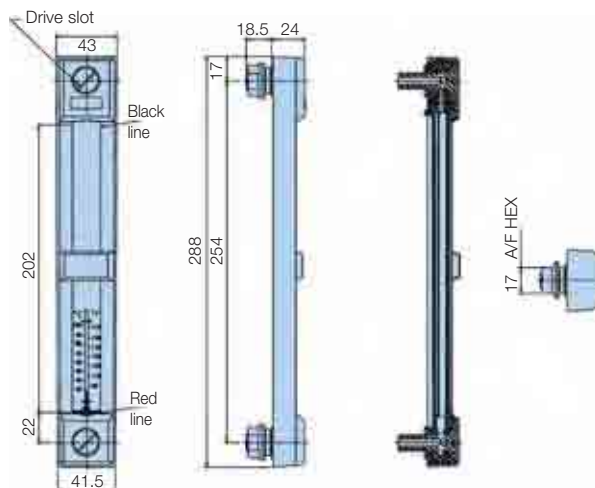

Size 3 Ordering Information

Standard products table

Part number	Supersedes	Description	Centres	Thread	Max temp	Weight
FL69321	FLT.321	Fluid level/temp	254mm	M10	90°C	0.23Kg
FL69323	FLT.323	Fluid level/temp	254mm	M12	90°C	0.23Kg
FL69311	FL.311	Fluid level	254mm	M10	90°C	0.23Kg
FL69313	FL.313	Fluid level	254mm	M12	90°C	0.23Kg

Note 1: Part numbers featured with bold highlighted codes will ensure a 'standard' product selection.

Note 2: Alternate displayed part number selection will require you to contact Parker Filtration for availability.

Reservoir Float & Level Switches

Reservoir Equipment



Cost effective reservoir solution

Float switches designed for on-site adjustment

A range of high quality, adjustable float switches. A reliable design using reed switches and available in 3 lengths – 500mm, 1000mm and 1500mm. Additionally a capacitive level switch is available designed to detect the loss of fluid below its position in the tank.



Contact Information:

Parker Hannifin
Hydraulic Filter Division Europe

European Product Information Centre
Freephone: 00800 27 27 5374
(from AT, BE, CH, CZ, DE, EE, ES, FI, FR, IE, IT, PT, SE, SK, UK)
filtrationinfo@parker.com

www.parkerhfde.com

Product Features:

- Adjustable float switches – 3 lengths available.
- Capacitive level switch designed to give a low level alarm.
- High quality, adjustable float switches available in 3 lengths – 500mm, 1000mm and 1500mm.
- Capacitive level switch – rugged construction, simple to install and with no moving components.
- Cost effective reservoir solutions with many applications.

FL Series

Adjustable Float Switch Reservoir Equipment

Features & Benefits



The **FL Series** is a range of vertically mounted, single float level switches operating on the proven reed switch and magnet principle.

The **FL Series** float switch can be tailored by the user for a particular application, by adjusting the length of the float switch tube. It is also possible for the user to select the switching configuration by inverting the float, giving either open on rise or close on rise operation.

The unit is supplied part assembled, with detailed instructions for the user to complete assembly to the specifications of the application and to install the unit.

Float Switch Features Include:

- Float switches can be adjusted on site
- Reliable design using reed switches
- 3 lengths available, 500mm, 1000mm and 1500mm

The **FL Series** is designed to be adjusted by the user to fit their tank. The unit consists of a stem with the reed switch and float already set in position. The customer can cut the stem to fit their tank, and assemble it to the header. The unit is then ready to be fitted to the tank.

The unit has a factory set "Open On Rise" switching configuration, but this can be changed by reversing the float.

Note: FL Series switches supplied as loose parts so no IP class applies. If assembled correctly by the customer, the IP class is IP67.

Typical Specification

Installation

Mounting: 1" BSP threaded header
Gasket: 2.0mm thick sealing washer
Length: Adjustable up to 1500mm

Electrical specification

Supply voltage: 240 Vac maximum
300 Vdc maximum

Switching current: 0.5A

Material specification

Header: Brass
Stem: Brass
Float: Polypropylene
Gasket: Klingersil grade C4324 to BS7531 grade Y

Other parameters

Fluid types: Any liquids compatible with brass and polypropylene

Installation Drawing

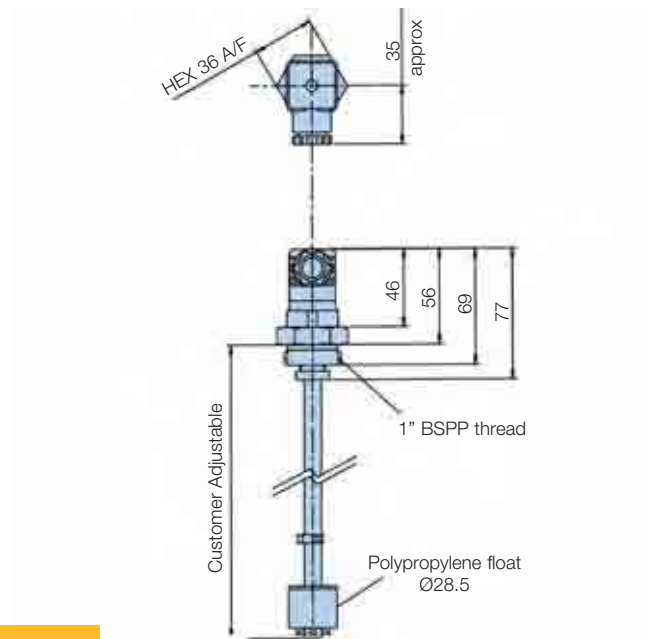

Ordering Information

Standard products table

Part number	Supersedes	Description
FL050010R	FL-0500-1-0R	500mm long float level switch
FL100010R	FL-1000-1-0R	1000mm long float level switch
FL150010R	FL-1500-1-0R	1500mm long float level switch

Note 1: Part numbers featured with bold highlighted codes will ensure a 'standard' product selection.

Note 2: Alternate displayed part number selection will require you to contact Parker Filtration for availability.

CLS46

Capacitive Level Switch Reservoir Equipment

Features & Benefits



The **CLS46 Liquid Level Switch** is an active device which is designed to give an alarm signal if fluid falls below a preset level. It will only give an output signal after a few seconds of low level to eliminate false alarms due to turbulence. The fact that the **CLS46 Series** has no moving parts and incorporates a built in delay means that it is ideal in applications where mechanically operated switches mis-trigger due to vibration and fluid turbulence.

Features Include:

- Rugged construction
- Simple to install
- Delay circuitry prevents false alarms
- Purely electronic, no moving components
- Integrated test feature

The **CLS46 Capacitive Level Switch** is designed to detect the loss of fluid below its position in the tank.

The **CLS46 Series** has no moving parts and it is therefore suitable for all applications, particularly where space and access inside a vessel is at a minimum.

The **CLS46 Series** compliments the existing range of level measurement instrumentation supplied by Parker Hannifin.

Technical Specification

Dimensions: See drawing

Electrical rating:

Supply voltage: 7-40 Vdc Supply current: 3.0mA
Max. load current: 1.0A Alarm delay time: 10.0 seconds

Connections:

V+: Positive power supply
GND: Negative power supply or GND
Output: Transistor switched to GND on alarm
Test: Ground to operate
Body: Connected to ground

Fluid types:

Mineral oils, typically used in engines or hydraulic actuators compatible with brass, PTFE and NBR.

Construction:

Body: Brass Probe: PTFE
Terminals: SAE CA210 brass, tin plated
Seals: NBR
Connector: 30% glass filled nylon 6

Environmental ratings

Max. pressure: 5.0 bar (72 PSI)
Temp. ranges: Fluid: -40°C to +130°C
Ambient: -40°C to +100°C
Storage: -50°C to +140°C

Sealing: IP67

Vibration: 6g 10-50Hz (600-3000rpm)

Shock: 50g, 6.3mS

Weight: 53g

Installation Details

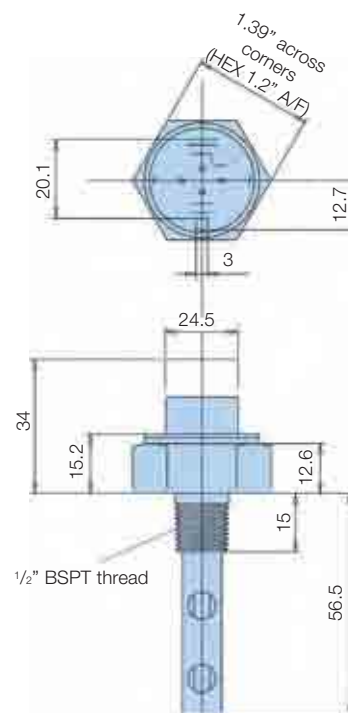

Ordering Information

Standard products table

Part number	Description
CLS46	Capacitive fluid level sensor
CLS46Connector	Capacitive fluid level sensor connector

Note 1: Part numbers featured with bold highlighted codes will ensure a 'standard' product selection.

Note 2: Alternate displayed part number selection will require you to contact Parker Filtration for availability.

Note 3: CLS46 does not include the connector.



Suction Elements

Reservoir Equipment



Proven solutions for oil reservoir efficiency

A range of quality fluid power products for reservoir and system application

A high quality range of products designed to complete a reservoir installation including in-tank suction strainers and oil diffusers, metal and polyester in-line filters and drive couplings with nylon sleeve and sintered steel couplings. Inline check valves, single station gauge isolator valve and 63mm/100mm pressure gauges are also available.



Contact Information:

Parker Hannifin
Hydraulic Filter Division Europe

European Product Information Centre
Freephone: 00800 27 27 5374
(from AT, BE, CH, CZ, DE, EE, ES, FI, FR, IE, IT, PT, SE, SK, UK)
filtrationinfo@parker.com

www.parkerhfde.com

Product Features:

- In-tank suction strainers and oil diffusers.
- Metal and polyester in-line filters and drive couplings.
- Inline check valves.
- Gauge isolator valves and 63mm/100mm pressure gauges.

Suction Elements

Reservoir Equipment

Specification



Construction:

Stainless steel media 30% glass filled nylon head. Zintec centre tube. Epoxy adhesives.

Maximum working temperature:
90°C.

Maximum clear element pressure drop:
0.03 bar.

Filtration media:
125 micron*.

Flow range:
15-500 l/min (for 30cst).

Bypass rating:
0.17 bar.

Mounting threads:

G¹/₂ up to G3.

* Non-standard elements are available to order. Consult Parker Filtration.

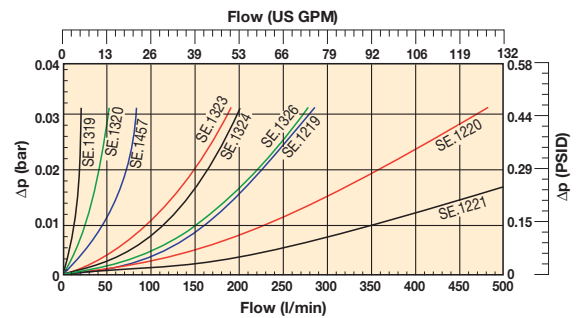

Installation - Suction Elements Without Bypass

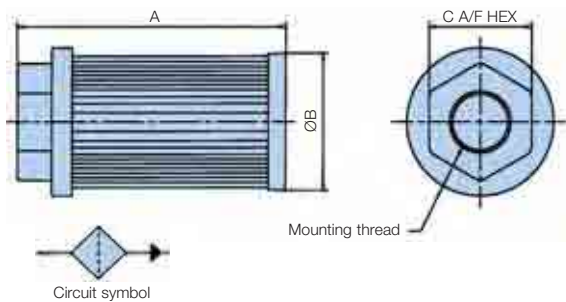

Installation - Suction Elements with Bypass

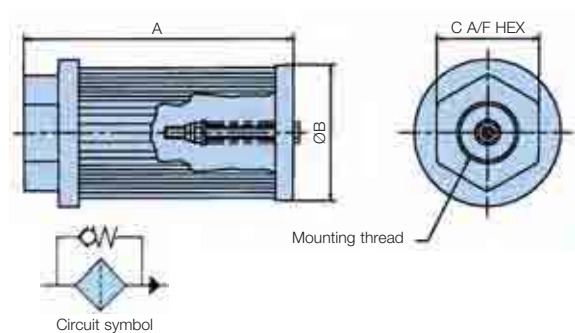

Ordering Information - Without Bypass

Standard products table

Part number	Supersedes	Flow l/min	Ports BSP	Micron rating	Dimensions (mm)			Weight	Bypass rating
					A	B	C		
SE75111110	SE.1319	15	1/2	125	105.5	46	36	0.08	N/A
SE75221110	SE.1320	25	3/4	125	109.5	64	46	0.15	N/A
SE75231210	SE.1457	50	1	125	139.5	64	55	0.17	N/A
SE75351210	SE.1323	95	1 1/2	125	140	86	65	0.28	N/A
SE75351310	SE.1324	130	1 1/2	125	200	86	65	0.33	N/A
SE75361410	SE.1326	180	2	125	260	86	75	0.40	N/A
SE75461210	SE.1219	225	2	125	150	150	70	0.64	N/A
SE75471310	SE.1220	350	2 1/2	125	212	150	90	0.72	N/A
SE75481410	SE.1221	500	3	125	272	150	100	0.92	N/A

Note 1: Part numbers featured with bold highlighted codes will ensure a 'standard' product selection.

Note 2: Alternate displayed part number selection will require you to contact Parker Filtration for availability.

Ordering Information - With Bypass

Standard products table

Part number	Supersedes	Flow l/min	Ports BSP	Micron rating	Dimensions (mm)			Weight	Bypass rating
					A	B	C		
SE75111111	SE.5100	15	1/2	125	105.5	46	36	0.08	0.17 bar
SE75221111	SE.5101	25	3/4	125	109.5	64	46	0.15	0.17 bar
SE75231211	SE.5102	50	1	125	139.5	64	55	0.17	0.17 bar
SE75351211	SE.5103	95	1 1/2	125	140	86	65	0.28	0.17 bar
SE75351311	SE.5104	130	1 1/2	125	200	86	65	0.33	0.17 bar
SE75361411	SE.5105	180	2	125	260	86	75	0.40	0.17 bar
SE75461211	SE.5106	225	2	125	150	150	70	0.64	0.17 bar
SE75471311	SE.5107	350	2 1/2	125	212	150	90	0.72	0.17 bar
SE75481411	SE.5108	500	3	125	272	150	100	0.92	0.17 bar

Note 1: Part numbers featured with bold highlighted codes will ensure a 'standard' product selection.

Note 2: Alternate displayed part number selection will require you to contact Parker Filtration for availability.



Diffusers

Reservoir Equipment

Installation Details



Specification

Construction:

Zintec body.
30% glass-filled nylon head.
Zintec end cap.
Epoxy adhesives.

Mounting threads:

G^{3/4} up to G2.

Temperature:

+ 90°C max.

Flow range:

50 l/min up to 454 l/min (For 30cSt).

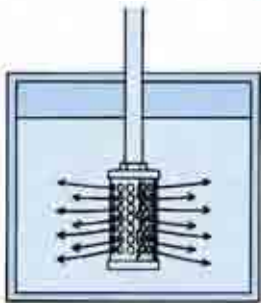
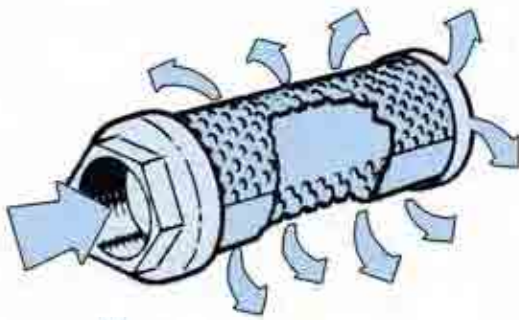
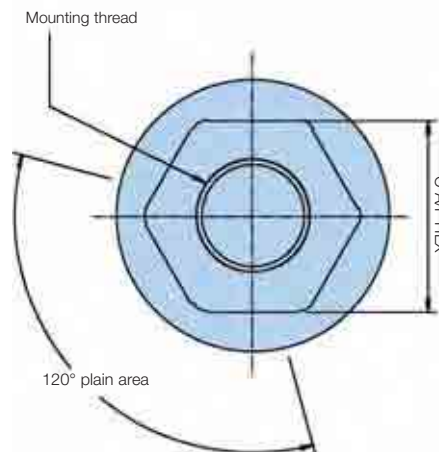
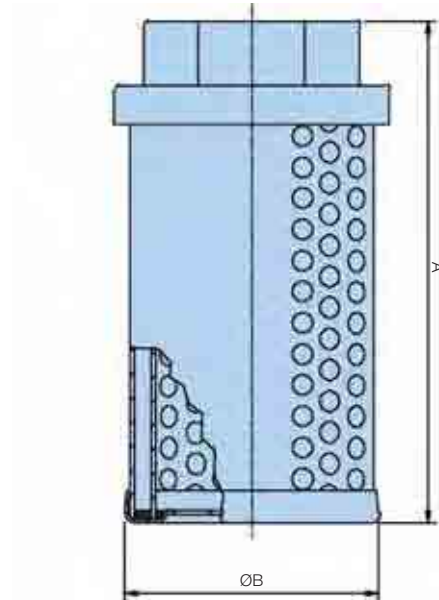

The effect of fitting a diffuser

Note: When installing a diffuser the plain area on the outside must be facing the pump inlet.

Note: For information relating to maximum differential pressure over the diffuser, consult Parker Filtration.

The benefits of specifying a Parker Filtration Diffuser

Installing a Parker Filtration Diffuser in a hydraulic reservoir is a simple operation that can make a big difference to system efficiency.

With its special concentric tubes designed with discharge holes 180° opposed fluid aeration, foaming and reservoir noise are reduced and pump life extended by reducing cavitation to the pump inlet.

Diffusers manufactured to customer specifications and other sizes of diffusers are available.

Ordering Information

Standard products table

Part number	Flow l/min	Ports BSP	Dimensions (mm)			Weight
			A	B	C	
2201	114	1	127	86	55	0.42
2202	227	1½	178	86	65	0.56
2210	50	¾	120	62	46	0.27
2203	454	2	242	86	75	0.69

Note 1: Part numbers featured with bold highlighted codes will ensure a 'standard' product selection.

Note 2: Alternate displayed part number selection will require you to contact Parker Filtration for availability.



Inline Filters

Reservoir Equipment

Metal Inline Filter - Specification



Construction:
Head – zinc.
Bowl – Aluminium
BS1470/1050A. 1987.
Element:
Zintec/Stainless steel.
125 micron*.

Max. flow:
90 l/min.
Max working pressure:
7 bar.
Thread:
G1.

Working temperature:
-30°C to +80°C.
Seal:
Nitrile.
Bowl tightening torque:
12 Nm.

Flow direction:
From outside to inside.
Weight:
1.5 Kg.
*Alternative media can be specified.

Installation Details

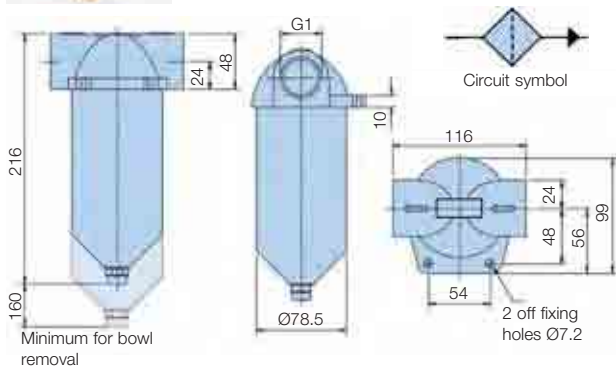

Filter Selection

Total assembly pressure drop flow curve
Oil Viscosity 30 cSt Relative density 0.856

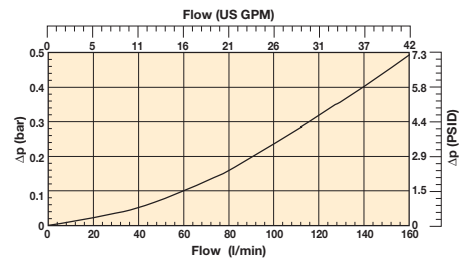

Ordering Information

Standard products table

Part number	Flow l/min	Thread BSP	Micron rating	Replacement element	Supersedes
IL1115	90	G1	125	EIL1115	E.IL.1115

Note 1: Part numbers featured with bold highlighted codes will ensure a 'standard' product selection.
Note 2: Alternate displayed part number selection will require you to contact Parker Filtration for availability.

Non-Corrodible Inline Filter - Specification



Construction:
Housing and bowl moulded in polyester.
Element:
Stainless steel mesh.
125 micron*.
Max. flow:
120 l/min.

Max working pressure:
7 bar.
Thread:
G1.
*For alternative media consult Parker Filtration
Note: When using with water, protect from

freezing.
Working temperature:
-30°C to +80°C.
(+60°C water).
Seal:
Nitrile.
Bowl tightening torque:
12 Nm.

Bowl tightening note:
A box or ring spanner is recommended.
Flow direction:
From outside to inside.
Weight:
0.5 Kg.

Installation Details

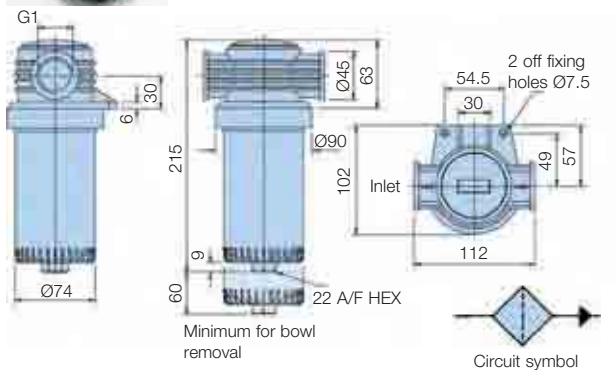

Total assembly pressure drop flow curve
Oil Viscosity 30 cSt Relative density 0.856

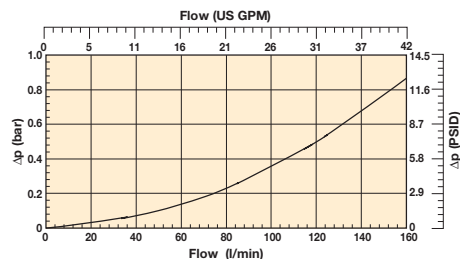

Ordering Information

Standard products table

Part number	Supersedes	Thread BSP	Appliance	Micron rating	Weight	Replacement element
IL761151	IL.1151	1	Oil	125	0.5	R.76115
IL761251	IL.1251	1	Water	125	0.5	R.76125

Note 1: Part numbers featured with bold highlighted codes will ensure a 'standard' product selection.
Note 2: Alternate displayed part number selection will require you to contact Parker Filtration for availability.



Drive Couplings

Reservoir Equipment

Technical Data



Materials

Coupling halves
Sintered Steel

Sleeve
Nylon 66

Max temp sleeve
83°C

To select coupling model check application to establish running load condition.

Check chart for factor (F) and apply factor (F) to *Rating of coupling formulae. This answer you now apply to *Rating/100 rev/min below.

It is advisable always to check shaft sizes being used on application and check with dimension 'H'.

Application	Factor (F)	
	Electric motor	Petrol/diesel engine
Uniform load	1.00	1.20
Medium shock	1.25	1.50
Heavy shock	1.75	2.00

$$\text{*Rating of coupling} = \frac{\text{HP of application} \times 100 \times F}{\text{rev/min of application}}$$

Installation Details

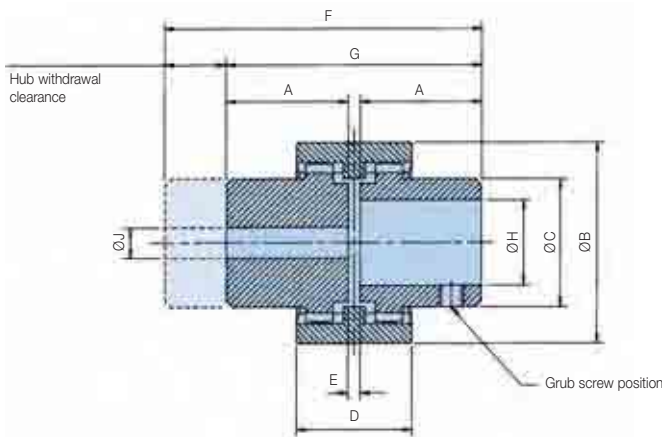

Sectioned detail

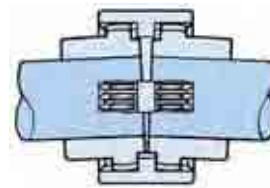

Part number prefix	Max speed rev/min	*Rating/ 100 rev/min		Weight	A mm	B mm	C mm	D mm	E mm	F mm	G mm	max bore	-H- min bore	J pilot bore
		kW	hp											
DC28*	5000	0.75	1.00	0.4	40.0	66.0	44.5	38.0	4.0	104.0	84.0	28.0	10.0	7.0
DC42*	5000	1.32	1.75	0.75	42.0	90.0	60.0	42.0	4.0	115.0	88.0	42.0	14.0	10.5
DC55*	4000	6.00	8.00	2.05	59.0	125.0	83.0	65.0	4.0	158.0	122.0	55.0	19.0	16.0 min 38.1 max

Height of keyway from base of bore

	Metric	Imperial
Standard bore	BS 4500, (1985)	BS 1916, Part 1, (1985)
Standard keyway	BS 4325, Part 1 (1980)	BS 46, Part 1, (1985)

Assembly data

- Maximum angular misalignment is ±2°. Maximum radial misalignment is ±0.4mm.
- Ensure that the Parker Filtration drive coupling gear hubs are an easy fit to their respective shafts. Do not use heavy blows to force the hubs on.
- When in position, the hubs should have a gap of 4mm as denoted by 'E' dimension.
- Tighten grub screws to locate both gear hubs on to their respective shafts.

Ordering Examples

Parker Filtration drive coupling components are ordered separately. Here are three examples of complete assemblies ordered this way.

- Complete assembly – **DC28M14B04K**
Made up of a **DC28M14**
DC28B04K
DC28.S (Sleeve)

Complete model **DC28** drive coupling: One gear hub has 14mm bore with 5mm wide keyway and other hub has a 1/2" bore with 0.125" wide keyway.

Both hubs supplied with locating grub screw.

- Complete assembly – **DCR42PBB**
Made up of 2x **DCR42PB's**
DC42S (Sleeve)

Complete model **DC42** drive coupling: Both gear hubs have pilot bore of 10.5mm. Not supplied with grub screws.

- Complete assembly – **DCR55PBB12K**
Made up of a **DCR55PB**
DC55B12K
DC55S (Sleeve)

Complete model **DC55** drive coupling: One gear hub pilot bored 5/8", the other hub pilot bored 1 1/2". Latter only supplied with grub screw.



Drive Couplings

Reservoir Equipment

Ordering Information

Model DC.28

Part number	Supersedes	Ø Bore (mm)	Keyway		Weight
			Width (mm)	Height (mm)	
DC28M16	DC.28.M16	16.0mm	5.0mm	18.4mm	Range from 0.259Kg to 0.411Kg
DC28M19	DC.28.M19	19.0mm	6.0mm	21.9mm	
DC28M20	DC.28.M20	20.0mm	6.0mm	22.9mm	
DC28M22	DC.28.M22	22.0mm	6.0mm	24.9mm	
DC28M24	DC.28.M24	24.0mm	8.0mm	27.5mm	
DC28M25	DC.28.M25	25.0mm	8.0mm	28.5mm	
DC28M28	DC.28.M28	28.0mm	8.0mm	31.5mm	
DCR28PB	DCR.28.PB	8.0mm	N/A	N/A	
DC28S	DC.28.S	N/A	N/A	N/A	
DC28M10	DC.28.M10	10.0mm	3.0mm	11.5mm	
DC28M11	DC.28.M11	11.0mm	4.0mm	12.9mm	
DC28M14	DC.28.M14	14.0mm	5.0mm	16.4mm	
DC28M18	DC.28.M18	18.0mm	6.0mm	20.9mm	
DC28B03K	DC.28.B03K	$\frac{7}{16}$	0.125 ins	0.50 ins	
DC28B04K	DC.28.B04K	$\frac{1}{2}$	0.125 ins	0.57 ins	
DC28B05K	DC.28.B05K	$\frac{5}{8}$	0.188 ins	0.72 ins	
DC28B06K	DC.28.B06K	$\frac{3}{4}$	0.188 ins	0.84 ins	
DC28B07K	DC.28.B07K	$\frac{7}{8}$	0.250 ins	0.99 ins	
DC28B08K	DC.28.B08K	1	0.250 ins	1.12 ins	
DC28B09K	DC.28.B09K	$1\frac{1}{8}$	0.313 ins	1.24 ins	

Model DC.42

Part number	Supersedes	Ø Bore (mm)	Keyway		Weight
			Width (mm)	Height (mm)	
DC42M25	DC.42.M25	25.0mm	8.0mm	28.5mm	Range from 0.436Kg to 0.753Kg
DC42M28	DC.42.M28	28.0mm	8.0mm	31.5mm	
DC42M30	DC.42.M30	30.0mm	8.0mm	33.5mm	
DC42M35	DC.42.M35	35.0mm	10.0mm	38.5mm	
DC42M38	DC.42.M38	38.0mm	10.0mm	41.5mm	
DC42M42	DC.42.M42	42.0mm	12.0mm	45.5mm	
DCR42PB	DCR.42.PB	12.0mm	N/A	N/A	
DC42S	DC.42.S	N/A	N/A	N/A	
DC42M18	DC.42.M18	18.0mm	6.0mm	20.9mm	
DC42M19	DC.42.M19	19.0mm	6.0mm	21.9mm	
DC42M20	DC.42.M20	20.0mm	6.0mm	22.9mm	
DC42M22	DC.42.M22	22.0mm	6.0mm	24.9mm	
DC42M24	DC.42.M24	24.0mm	8.0mm	27.5mm	
DC42M32	DC.42.M32	32.0mm	10.0mm	35.5mm	
DC42B05K	DC.42.B05K	$\frac{5}{8}$	0.188 ins	0.72 ins	
DC42B06K	DC.42.B06K	$\frac{3}{4}$	0.188 ins	0.84 ins	
DC42B07K	DC.42.B07K	$\frac{7}{8}$	0.250 ins	0.99 ins	
DC42B08K	DC.42.B08K	1	0.250 ins	1.12 ins	
DC42B09K	DC.42.B09K	$1\frac{1}{8}$	0.313 ins	1.24 ins	
DC42B10K	DC.42.B10K	$1\frac{1}{4}$	0.313 ins	1.37 ins	
DC42B11K	DC.42.B11K	$1\frac{3}{8}$	0.375 ins	1.49 ins	
DC42B12K	DC.42.B12K	$1\frac{1}{2}$	0.375 ins	1.61 ins	
DC42B13K	DC.42.B13K	$1\frac{5}{8}$	0.439 ins	1.76 ins	

Model DC.55

Part number	Supersedes	Ø Bore (mm)	Keyway		Weight
			Width (mm)	Height (mm)	
DCR55PB	DCR.55.PB	16.0mm	N/A	N/A	Range from 1.248 Kg – 2.046 Kg
DC55S	DC.55.S	N/A	N/A	N/A	
DC55M25	DC.55.M25	25.0mm	8.0mm	28.5mm	
DC55M28	DC.55.M28	28.0mm	8.0mm	33.5mm	
DC55M30	DC.55.M30	30.0mm	8.0mm	33.5mm	
DC55M32	DC.55.M32	32.0mm	10.0mm	35.5mm	
DC55M35	DC.55.M35	35.0mm	10.0mm	38.5mm	
DC55M38	DC.55.M38	38.0mm	10.0mm	41.5mm	
DC55M42	DC.55.M42	42.0mm	12.0mm	45.5mm	
DC55M55	DC.55.M55	55.0mm	16.0mm	59.5mm	
DC55B09K	DC.55.B09K	$1\frac{1}{8}$	0.313 ins	1.24 ins	
DC55B10K	DC.55.B10K	$1\frac{1}{4}$	0.313 ins	1.37 ins	
DC55B11K	DC.55.B11K	$1\frac{3}{8}$	0.375 ins	1.49 ins	
DC55B12K	DC.55.B12K	$1\frac{1}{2}$	0.375 ins	1.61 ins	
DC55B13K	DC.55.B13K	$1\frac{5}{8}$	0.439 ins	1.76 ins	
DC55B14K	DC.55.B14K	$1\frac{3}{4}$	0.439 ins	1.89 ins	
DC55B15K	DC.55.B15K	$1\frac{7}{8}$	0.501 ins	2.01 ins	
DC55B16K	DC.55.B16K	2	0.501 ins	2.13 ins	
DC55B17K	DC.55.B17K	$2\frac{1}{8}$	0.626 ins	2.31 ins	

Note 1: Part numbers featured with bold highlighted codes will ensure a 'standard' product selection.

Note 2: Alternate displayed part number selection will require you to contact Parker Filtration for availability.

Note 3:* Width and height apply to dimensions of the **Keyway**.



Multiclamp

Pipe Clamp System



A 'fit for purpose' pipe clamping system

Leak free, noise free and vibration free pipe clamping

Multiclamp is a system of components, each one engineered to a high standard – that together build to provide effective, all-purpose pipe work clamping. Available as single clamp, double clamp, 12 or 16 hole Multiclamp, there is a complete range of split bushes to accept pipe or hose diameters from 6mm up to 50mm from 3 x Series of Multiclamp.

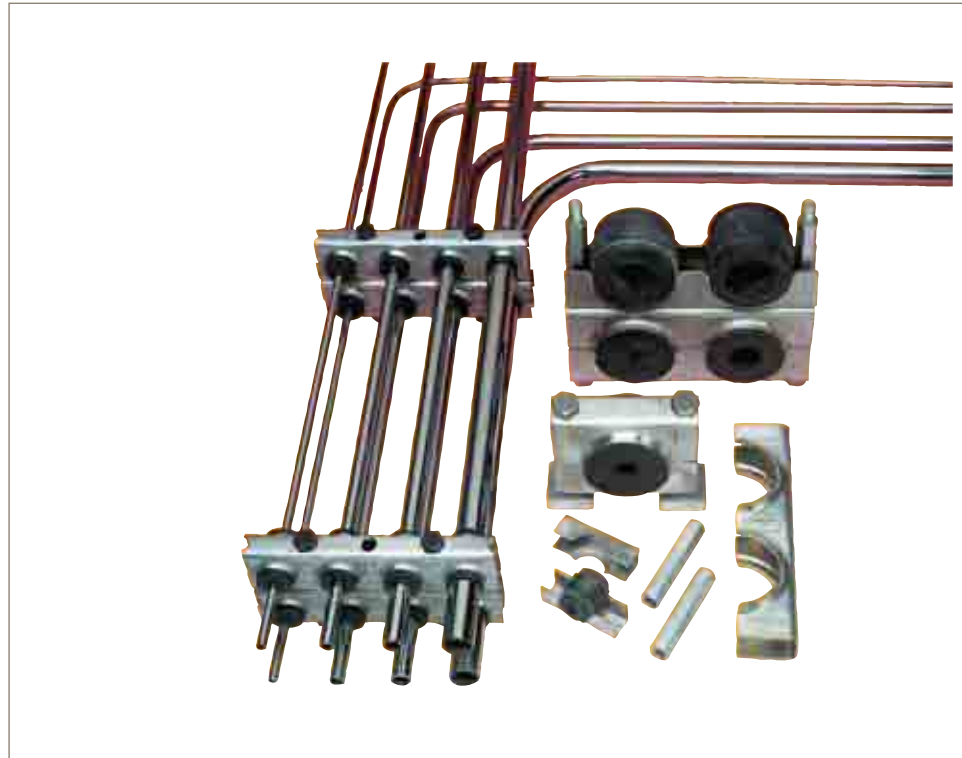

Contact Information:

Parker Hannifin
Hydraulic Filter Division Europe

**European Product
Information Centre**
Freephone: 00800 27 27 5374
(from AT, BE, CH, CZ, DE, EE, ES,
FI, FR, IE, IT, PT, SE, SK, UK)
filtrationinfo@parker.com

www.parkerhfde.com

Product Features:

- High quality pipe clamping system in 3 ranges - Series 10, 16 or 32.
- Pipe or hose diameters from 6mm up to 50mm.
- 26 different diameter, high quality split rubber bushes.
- Zinc plated steel construction with anti-corrosive, full passivate.
- Stainless Steel clamp available.



When only the best Clamping System will dospecify Multiclamp

Multiclamp is a system. A system of components, each one engineered to a high standard – that together build to provide effective, all-purpose pipework clamping. Multiclamp offers creative and cost-effective environmental benefits to the system designer and installer. Creating accurate runs of varying diameter tubes, pipes, hoses and cables in all industries.

Secure Multiclamp installations ensure a leak free, noise free and vibration free system.

The neat design of pipe line runs offers easy maintenance of machinery and plant equipment. Visual planning of line runs is straightforward with Multiclamp – accurate installations can be achieved without skilled labour – keeping costs down and quality up.

Planning with Multiclamp

These notes have been compiled to assist in planning your Multiclamp system.

Multiclamp offers considerable flexibility. For example, it can fit in with a factory installation that is being built in phases.

Should a last minute change in pipe diameter occur during installation, an alternative rubber bush is likely to be all that is required. Not a complete and expensive re-think of the installation.

Multiclamp metal components can be sprayed to match a vehicle livery or plant installation and, if installed properly, should require no maintenance.

Installation is simple and requires no experience

Anyone can use Multiclamp and only the basic, everyday tools are required.

From one pipe to almost any number – because each Multiclamp ‘position’ can be visually sighted and its position adjusted – an almost guaranteed straight run can be obtained. Equally, changes of plane or direction can be achieved simply and securely.

Group pipe sizes together to obtain the most economical use of three basic Multiclamp Series.

Some sites will require all pipes mounted in one single plane – either vertical or horizontal.

When stacked modules are preferred, the only work to be done on the Multiclamp is to saw off the desired length.

If a large number of pipe lines are to be run, it is recommended that the upper clamping unit is simply cut into two lines only, and progressively assembled by securing two pipes at a time. It will be recognised that most odd lengths on site will be used, and one man can easily cope with a large number of pipe lines by this simple progressive build up. This assembly will provide easy access for servicing and replacing pipes. This method also reduces the quantity of Stacking Nuts and Studs by 50%.

If a factory installation is being built in phases, it would be wise to leave the first phase with a lower clamping unit and Stacking Nuts in position ready to receive pipe runs for the next building phase.

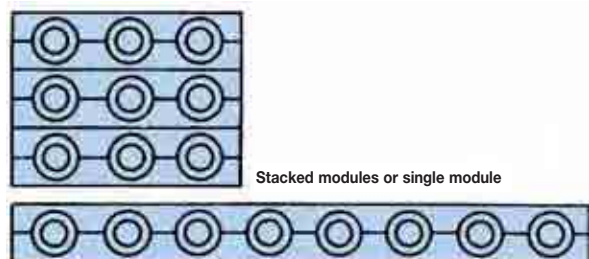
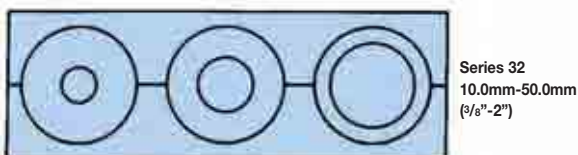
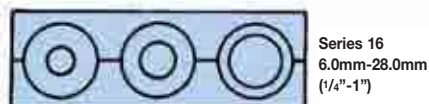

Your maximum pipe size will determine the series to use. There is a degree of versatility provided by the rubber bushes. You choose from single or multistacked Multiclamp, whichever suits your particular installation requirements.



Multiclamp

Pipe Clamp System

Specification

Dimension details supplied in product configurator

Single Clamp

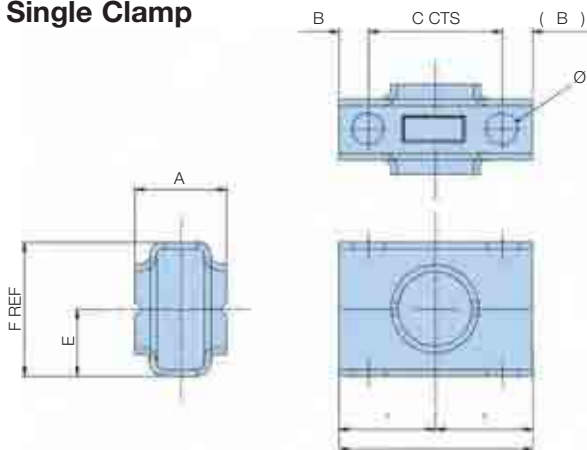

Double Clamp

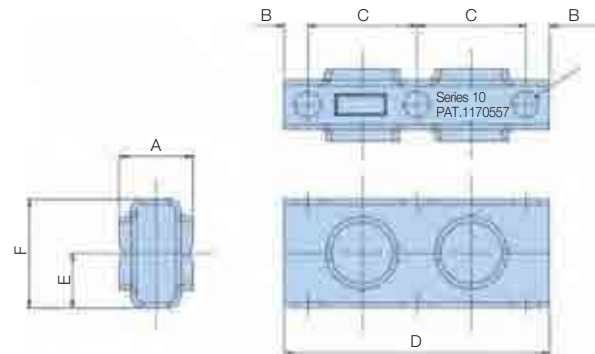

Multiclamp – 12 or 16 holes

1 set of clamping units = 1 pair

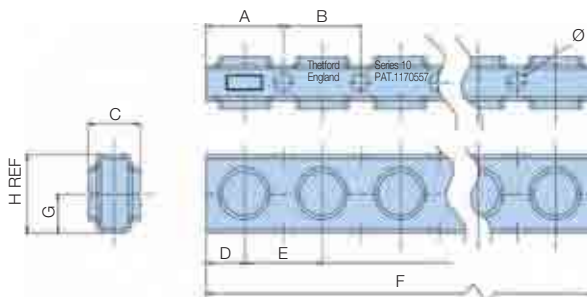

Split Bushes

Split bushes are ordered in sets only
i.e. 1 set of bushes = 10 bushes of one size

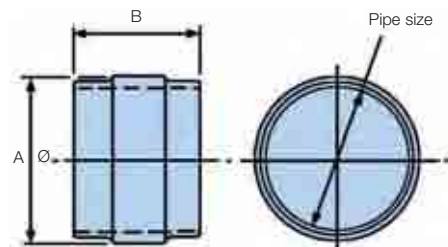

Material Specifications

Zinc plated steel with anti-corrosive, full passivate. Multiclamp can also be multi-stacked using stacking studs and nuts. Series 10 and 16 clamp is supplied in lengths of 603mm and Series 32 in lengths of 1206mm. These can be simply cut to the required lengths for installation.

Note: For stainless steel version please consult Parker.

Series 10 will accept pipe or hose diameters from 6mm up to 20mm maximum. Series 16 from 6mm up to 28mm and Series 32 from 10mm up to 50mm. Across the 3 Series, there are 26 different high-quality split rubber bushes to select from to cope with any combination and number of different pipe and hose diameters in the same run.

Stacking Nuts

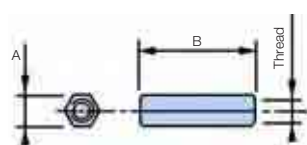

Stacking nuts are ordered in sets only.
i.e. 1 set of stacking nuts = 50 stacking nuts of one size.

Stacking Studs

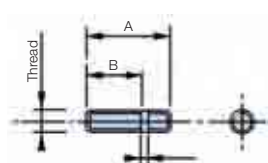

Stacking studs are ordered in sets only.
i.e. 1 set of stacking studs = 50 stacking studs of one size.

Mounting Adaptors

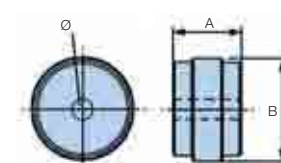

Mounting adaptors are not ordered in sets.
i.e. 1 off mounting adaptors = 1 single piece.

Weld Plate

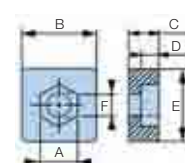

Weld plates are ordered in sets only.
i.e. 1 set of weld plates = 10 weld plates.



Ordering Information - Series 10

Product configurator

Part number	Supersedes	Description	Pack quantity	Dimensions (mm)								Thread	Pack weight	
				A	B	C	D	E	F	G	H			Ø
MC101	MC.10.1	Single clamp	10 pairs	25.0	8.5	38.1	55.0	19.0	38.0				9.0	0.60 Kg
MC102	MC.10.2	Double clamp	10 pairs	25.0	8.5	38.1	93.0	19.0	38.0				9.0	1.00 Kg
MC1016	MC.10.16	16 bay clamp	1 pair	34.0	38.1	25.0	15.0	38.1	601.5	19.0	38.0	9.0		0.80 Kg
MCN10	MC.N.10	Stacking nut	50	11.0	33.0								M8 x 1.25	0.80 Kg
MCS10	MC.S.10	Stacking stud	50	32.0	21.0	2.6							M8 x 1.25	0.50 Kg
MCWP10	MC.WP.10	Weld plate	10	13.3	25.0	10.0	6.3	25.0	8.5					0.35 Kg
MCSB10	MC.SB.10	Standard bolt	50	27.0									M8 x 1.25	0.55 Kg
MCB10MO	MC.B.10.MO	Mounting adaptor	1		25.0								8.7	0.02 Kg

Part number	Supersedes	Description	Pack quantity	Dimensions (mm)		Pipe size		Pack weight
				A	B	(mm)	OD	
MCG105	MC.G.10.5	Split bush	10	25.5	27.0	8	5/16	0.13 Kg
MCG106	MC.G.10.6	Split bush	10	25.5	27.0	10	3/8	0.12 Kg
MCG108	MC.G.10.8	Split bush	10	25.5	27.0	12-14	1/2	0.12 Kg
MCG1010	MC.G.10.10	Split bush	10	25.5	27.0	15-16	5/8	0.10 Kg
MCG1012	MC.G.10.12	Split bush	10	25.5	27.0	18-20	3/4	0.90 Kg
MCG104	MC.G.10.4	Split bush	10	25.5	27.0	6	1/4	0.13 Kg

Note 1: Part numbers featured with bold highlighted codes will ensure a 'standard' product selection.

Note 2: Alternate displayed part number selection will require you to contact Parker Filtration for availability.

Ordering Information - Series 16

Product configurator

Part number	Supersedes	Description	Pack quantity	Dimensions (mm)								Thread	Pack weight	
				A	B	C	D	E	F	G	H			Ø
MC161	MC.16.1	Single clamp	10 pairs	25.0	7.0	50.8	65.0	23.8	47.6				9.0	0.80 Kg
MC162	MC.16.2	Double clamp	10 pairs	25.0	7.0	50.8	116.0	23.8	47.6				9.0	1.60 Kg
MC1612	MC.16.12	12 bay clamp	1 pair	47.0	50.8	25.0	21.0	50.8	608.8	25.0	51.0	9.0		1.00 Kg
MCN16	MC.N.16	Stacking nut	50	11.0	44.0								M8 x 1.25	1.06 Kg
MCS10	MC.S.10	Stacking stud	50	32.0	21.0	2.6							M8 x 1.25	0.50 Kg
MCWP10	MC.WP.10	Weld plate	10	13.3	25.0	10.0	6.3	25.0	8.5					0.35 Kg
MCSB10	MC.SB.10	Standard bolt	50										M8 x 1.25	0.55 Kg
MCB16MO	MC.B.16.MO	Mounting adaptor	1	27.0	36.0								8.7	0.06 Kg

Part number	Supersedes	Description	Pack quantity	Dimensions (mm)		Pipe size		Pack weight
				A	B	(mm)	OD	
MCG165	MC.G.16.5	Split bush	10	35.4	27.0	8	5/16	0.28 Kg
MCG166	MC.G.16.6	Split bush	10	35.4	27.0	10	3/8	0.28 Kg
MCG168	MC.G.16.8	Split bush	10	35.4	27.0	12-14	1/2	0.26 Kg
MCG1610	MC.G.16.10	Split bush	10	35.4	27.0	15-16	5/8	0.22 Kg
MCG1612	MC.G.16.12	Split bush	10	35.4	27.0	18-20	3/4	0.20 Kg
MCG1614	MC.G.16.14	Split bush	10	35.4	27.0	22.0	7/8	0.18 Kg
MCG1616	MC.G.16.16	Split bush	10	35.4	27.0	25.0	1	0.14 Kg
MCG1618	MC.G.16.18	Split bush	10	35.4	27.0	28.0		0.16 Kg
MCG164	MC.G.16.4	Split bush	10	35.4	27.0	6	1/4	0.28 Kg

Note 1: Part numbers featured with bold highlighted codes will ensure a 'standard' product selection.

Note 2: Alternate displayed part number selection will require you to contact Parker Filtration for availability.

Multiclamp

Pipe Clamp System

Ordering Information - Series 32

Product configurator

Part number	Supersedes	Description	Pack quantity	Dimensions (mm)								Thread	Pack weight	
				A	B	C	D	E	F	G	H			Ø
MC321	MC.32.1	Single clamp	10 pairs	40.0	9.4	76.2	95.0	38.0	76.2				11.1	2.25 Kg
MC322	MC.32.2	Double clamp	10 pairs	41.0	9.4	76.2	171.0	38.0	76.2				11.1	3.82 Kg
MC3216	MC.32.16	16 bay clamp	1 pair	72.0	76.2	40.0	34.0	76.2	1211.0	38.5	77.0	11.0		3.80 Kg
MCN32	MC.N.32	Stacking nut	50	13.0	71.5								M10 x 1.5	1.99 Kg
MCS32	MC.S.32	Stacking stud	50	38.0	22.0	4.0							M10 x 1.5	0.90 Kg
MCWP32	MC.WP.32	Weld plate	10	17.5	32.0	12.0	8.0	32.0	11.0					0.70 Kg
MCSB32	MC.SB.32	Standard bolt	50										M10 x 1.5	1.30 Kg
MCB32MO	MC.B.32.MO	Mounting adaptor	1	40.0	58.0							10.7		0.26 Kg

Part number	Supersedes	Description	Pack quantity	Dimensions (mm)		Pipe size		Pack weight
				A	B	(mm)	OD	
MCG3210	MC.G.32.10	Split bush	10	59.0	44.5	15-16	5/8	1.10 Kg
MCG3212	MC.G.32.12	Split bush	10	59.0	44.5	18-20	3/4	1.10 Kg
MCG3216	MC.G.32.16	Split bush	10	59.0	44.5	25	1	1.00 Kg
MCG3218	MC.G.32.18	Split bush	10	59.0	44.5	28-30		1.00 Kg
MCG3220	MC.G.32.20	Split bush	10	59.0	44.5	32-34	1 1/4	0.80 Kg
MCG3224	MC.G.32.24	Split bush	10	59.0	44.5	35-38	1 1/4	0.80 Kg
MCG3232	MC.G.32.32	Split bush	10	59.0	44.5	50	2	0.40 Kg
MCG326	MC.G.32.6	Split bush	10	59.0	44.5	10	3/8	1.30 Kg
MCG328	MC.G.32.8	Split bush	10	59.0	44.5	12-14	1/2	1.20 Kg
MCG3214	MC.G.32.14	Split bush	10	59.0	44.5	22	7/8	1.00 Kg
MCG3226	MC.G.32.26	Split bush	10	59.0	44.5	42		0.60 Kg

Note 1: Part numbers featured with bold highlighted codes will ensure a 'standard' product selection.

Note 2: Alternate displayed part number selection will require you to contact Parker Filtration for availability.

How to 'build' Multiclamp

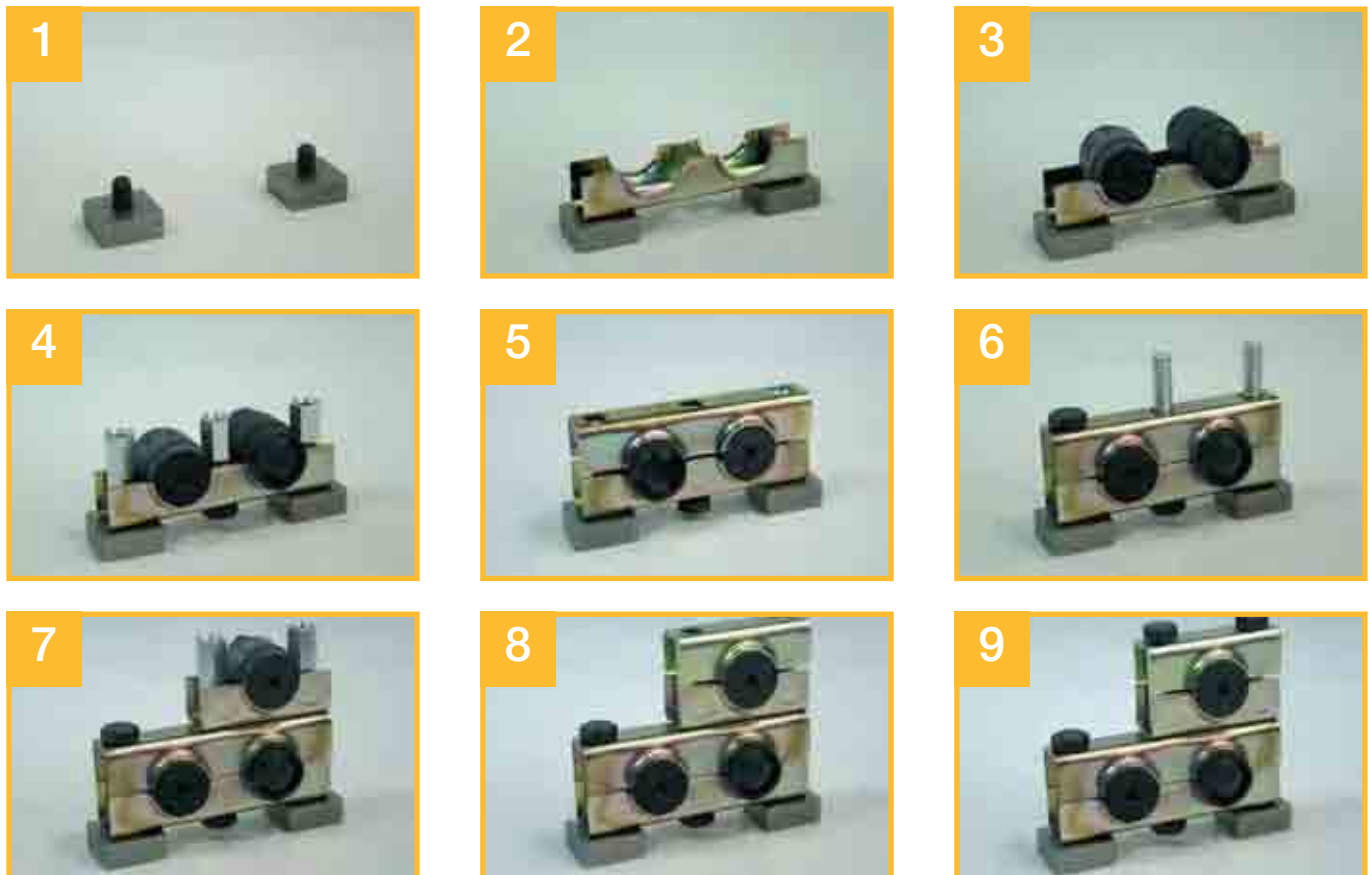

Inline Check Valves

Reservoir Equipment

Specification



Construction:
Steel UNI 5105.

Ball and spring:
Chrome finished steel.

Retainer:
Nylon.

Flow rates:
From 20 l/min to 150 l/min.

Max. working pressure:
350 bar.

Valve crack pressures:
0.35 and 4.5 bar.

Max. operating temp:
120°C.

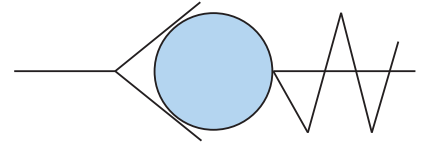

Circuit symbol

Installation Details

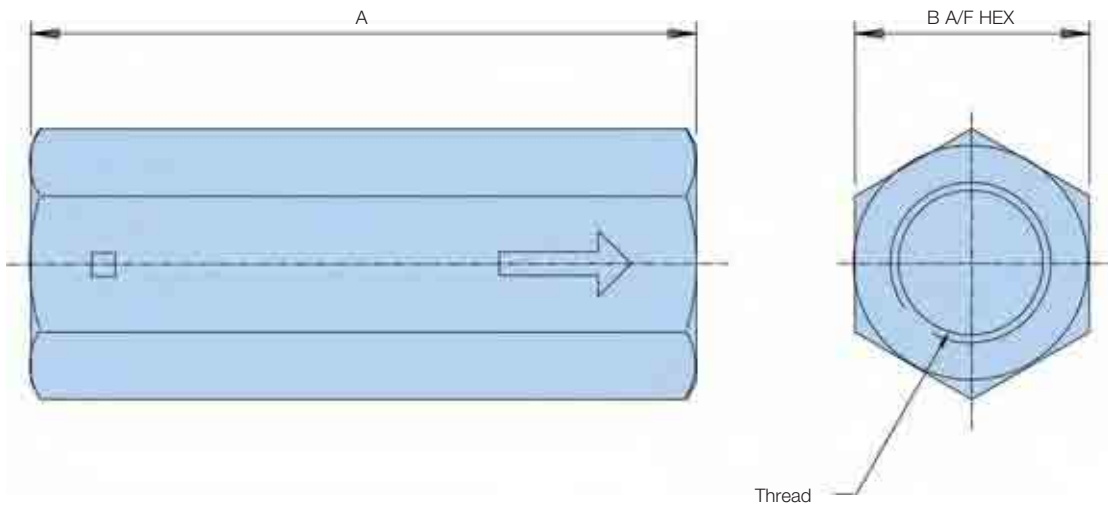

Technical Data

Pressure Drop Flow Curves

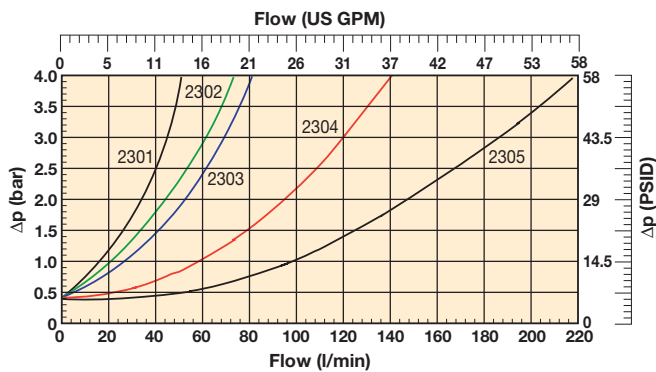

Ordering Information

Standard products table

Part number	Flow l/min	Cracking pressure bar	Thread G	A mm	B mm	Weight Kg
2301	20	0.35	1/4	54	19	0.09
2302	30	0.35	3/8	66	24	0.17
2303	50	0.35	1/2	77	30	0.32
2304	100	0.35	3/4	88	36	0.48
2305	150	0.35	1	108	46	0.99
2311	20	4.50	1/4	54	19	0.09
2312	30	4.50	3/8	65	24	0.17
2313	50	4.50	1/2	77	30	0.32
2314	100	4.50	3/4	88	36	0.48
2315	150	4.50	1	108	46	0.99

Single Station Gauge Isolator Valves

Reservoir Equipment

Specification



Construction:

Single Station: Cast iron and steel. Knurled plastic knob with 'Twist to lock' or 'push to read' type.

Max. working pressure:
350 bar.

Port size:

Single Station: G¹/₄.

Weight:

Single Station: 0.90 Kg.

Single Station Installation Details

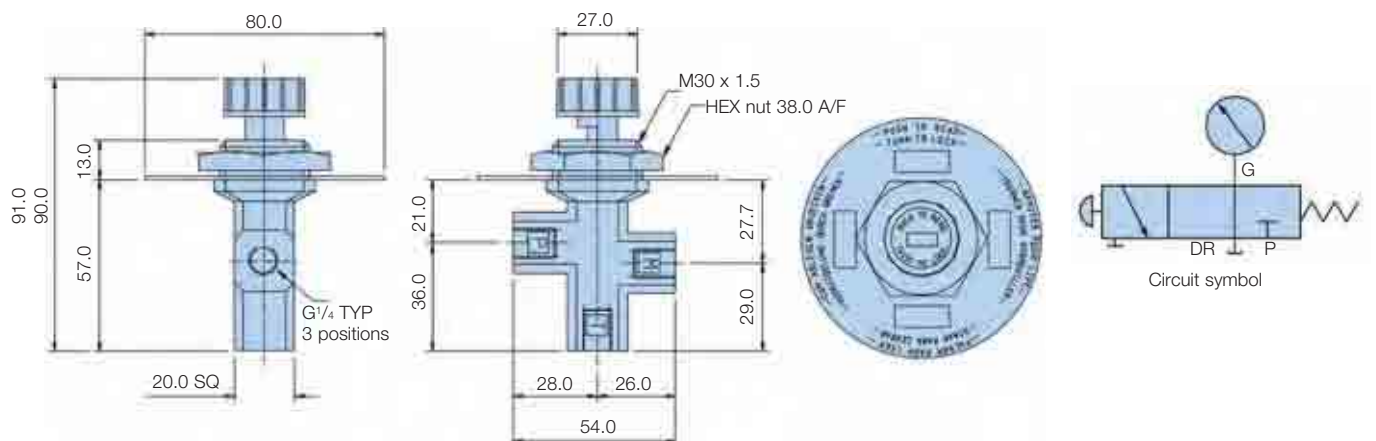

Operation Details

Single Station

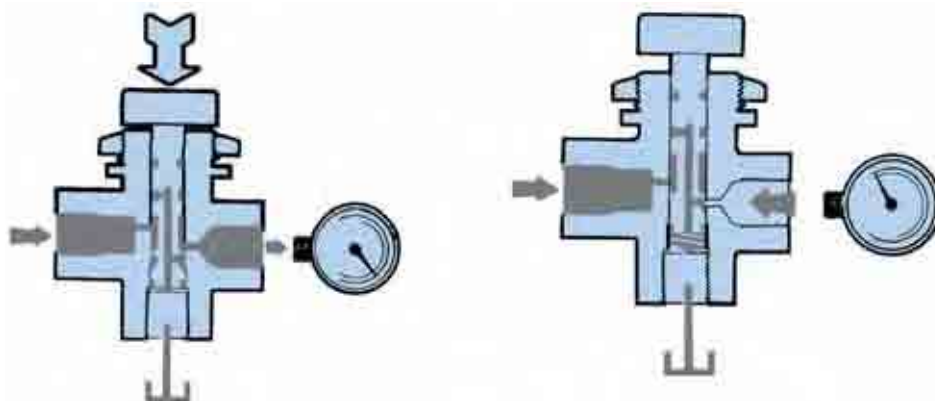

Ordering Information

Standard products table

Part number	Description	Weight
G11486	Single station gauge isolator "twist to lock" type	0.90 Kg
G11414	Single station gauge isolator "push to read" type	0.90 Kg

63mm Dia. Pressure Gauges

Reservoir Equipment

Specification



Construction:

Case: Natural finish stainless steel.
 Window: Non-splintering clear acrylic glass.
 Movement: Cu alloy.
 Dial: White plastic, with pointer stop pin.
 Pointer: Black plastic.

Liquid filling:

Glycerine 99.7%.

Working pressure:

Max 75% of the full scale value.

Process temperature range:

0°C to 60°C maximum.

Accuracy:

1.6% FSD.

Wetted parts connector:

Copper alloy.

Bourdon tube:

< 60 bar = Cu alloy, C-type, soft soldered.
 > 60 bar = Cu alloy, helical type, soft soldered.

IP Class:

IP65.

Mounting Stem Detail

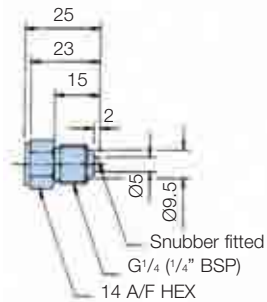

Note: It is recommended that all glycerine gauges should be mounted in the vertical position with gauge case relief valve uppermost. Pressure range up to 1000 bar available.

Ordering Information

Bottom Connection

Part number	Supersedes	Pressure range	Connector type
PGB0631010	PGC.0631.010	0-10 bar	G $\frac{1}{4}$ Bottom
PGB0631016	PGC.0631.016	0-16 bar	G $\frac{1}{4}$ Bottom
PGB0631025	PGC.0631.025	0-25 bar	G $\frac{1}{4}$ Bottom
PGB0631040	PGC.0631.040	0-40 bar	G $\frac{1}{4}$ Bottom
PGB0631060	PGC.0631.060	0-60 bar	G $\frac{1}{4}$ Bottom
PGB0631100	PGC.0631.100	0-100 bar	G $\frac{1}{4}$ Bottom
PGB0631160	PGC.0631.160	0-160 bar	G $\frac{1}{4}$ Bottom
PGB0631250	PGC.0631.250	0-250 bar	G $\frac{1}{4}$ Bottom
PGB0631400	PGC.0631.400	0-400 bar	G $\frac{1}{4}$ Bottom
PGB0631600	PGC.0631.600	0-600 bar	G $\frac{1}{4}$ Bottom
PGB0631004	PGC.0631.004	0-4 bar	G $\frac{1}{4}$ Bottom

Installation Details

Bottom Connection

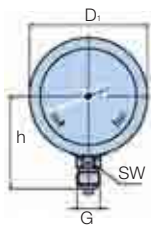

Panel Mounting (Centre Back)

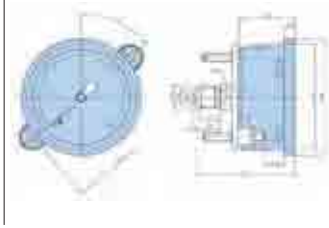

Dimensions (mm)

a	b	D ₁	D ₂	e	G	h	SW	Weight Kg
13	32 ±0.5	68	62	6.5	G $\frac{1}{4}$	54 ±1	14	0.21

Bottom Connection

Dimensions (mm)

b	b ₂	D ₁	D ₂	e	G	SW	Weight Kg
32 ±0.5	56 ±1	68	62	6.5	G $\frac{1}{4}$	14	0.21

Panel Mounting (Lower Back)

Note 1: Panel cut-out 64.5 ±0.5

Note 2: 13mm on the outside radius required to allow for fixing clamp.

Panel Mounted (3-hole flange)

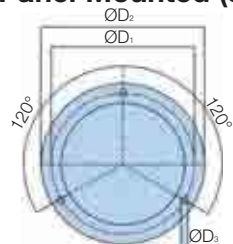

Note 1: Gauge dimensions as for panel mounting option above with flange as shown below.
 Note 2: Panel cut-out for 3-hole mounting 67±0.3.

Dimensions (mm)

D1	D2	D3
75	85	3.6

Panel Mounting

Part number	Supersedes	Pressure range	Connector type
PGC0631010	PGC.0631.010	0-10 bar	G $\frac{1}{4}$ Panel
PGC0631016	PGC.0631.016	0-16 bar	G $\frac{1}{4}$ Panel
PGC0631025	PGC.0631.025	0-25 bar	G $\frac{1}{4}$ Panel
PGC0631040	PGC.0631.040	0-40 bar	G $\frac{1}{4}$ Panel
PGC0631060	PGC.0631.060	0-60 bar	G $\frac{1}{4}$ Panel
PGC0631100	PGC.0631.100	0-100 bar	G $\frac{1}{4}$ Panel
PGC0631160	PGC.0631.160	0-160 bar	G $\frac{1}{4}$ Panel
PGC0631250	PGC.0631.250	0-250 bar	G $\frac{1}{4}$ Panel
PGC0631400	PGC.0631.400	0-400 bar	G $\frac{1}{4}$ Panel
PGC0631004	PGC.0631.004	0-4 bar	G $\frac{1}{4}$ Panel
PGC0631600	PGC.0631.600	0-600 bar	G $\frac{1}{4}$ Panel

Panel Mounted (3-hole flange)

Part number	Supersedes	Pressure range	Connector type
PGF0631060	PGF.0631.060	0-60 bar	G $\frac{1}{4}$ Panel Flange
PGF0631100	PGF.0631.100	0-100 bar	G $\frac{1}{4}$ Panel Flange
PGF0631160	PGF.0631.160	0-160 bar	G $\frac{1}{4}$ Panel Flange
PGF0631250	PGF.0631.250	0-250 bar	G $\frac{1}{4}$ Panel Flange
PGF0631400	PGF.0631.400	0-400 bar	G $\frac{1}{4}$ Panel Flange
PGF0631004	PGF.0631.004	0-4 bar	G $\frac{1}{4}$ Panel Flange
PGF0631010	PGF.0631.010	0-10 bar	G $\frac{1}{4}$ Panel Flange
PGF0631016	PGF.0631.016	0-16 bar	G $\frac{1}{4}$ Panel Flange
PGF0631025	PGF.0631.025	0-25 bar	G $\frac{1}{4}$ Panel Flange
PGF0631040	PGF.0631.040	0-40 bar	G $\frac{1}{4}$ Panel Flange
PGF0631600	PGF.0631.600	0-600 bar	G $\frac{1}{4}$ Panel Flange

Note 1: Part numbers featured with bold highlighted codes will ensure a 'standard' product selection.

Note 2: Alternate displayed part number selection will require you to contact Parker Filtration for availability.

*Note 3: Any subsequent changes to gauge accuracy will be notified.

100mm Dia. Pressure Gauges

Reservoir Equipment

Specification



Construction:

Case: BS 304 S15 stainless steel.
 Window: Acrylic.
 Movement: Brass.
 Dial: White aluminium.
 Pointer: Black aluminium.

Liquid filling:
 Glycerine 98%.

Working pressure:
 Full scale value.

Process temperature range:
 -20°C to +60°C maximum.

Accuracy:
 1.0% FSD.

Wetted parts connector:
 Copper alloy.

Bourdon tube:
 < 100 bar = Cu alloy, c-type, soft soldered.
 > 100 bar = stainless steel 1.4571, helical type, brazed.

IP Class:
 IP65.

Mounting Stem Detail

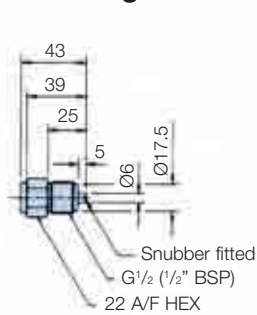

Note: It is recommended that all glycerine gauges should be mounted in the vertical position with gauge case relief valve uppermost.

Installation Details

Bottom Connection

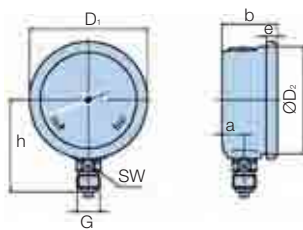

Panel Mounting (Lower Back)

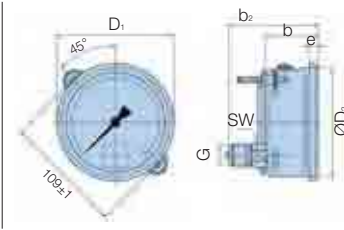

Dimensions (mm)

Bottom Connection								
a	b ±0.5	D ₁	D ₂	e	G	h ±1	SW	Weight Kg
15.5	48	107	100	8	G _{1/2}	87	22	0.80

Dimensions (mm)

Panel Mounting (Lower Back)							
b ±0.5	b ₂ ±1	D ₁	D ₂	e	G	SW	Weight Kg
48	81.5	107	100	8	G _{1/2}	22	0.80

Note 1: Panel cut-out 102 ±1.0

Note 2: 13mm on the outside radius required to allow for fixing clamp.

Panel Mounted (3-hole flange)

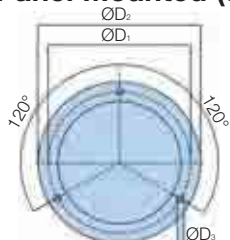

Note 1: Gauge dimensions as for panel mounting option above with flange as shown below.

Note 2: Panel cut-out for 3-hole mounting 104 ±0.5.

Dimensions (mm)

D ₁	D ₂	D ₃
116	132	4.8

Ordering Information

Bottom Connection

Part number	Supersedes	Pressure range	Connector type
PGB1001250	PGB.1001.250	0-250 bar	G _{1/2} Bottom
PGB1001400	PGB.1001.400	0-400 bar	G _{1/2} Bottom
PGB1001010	PGB.1001.010	0-10 bar	G _{1/2} Bottom
PGB1001016	PGB.1001.016	0-16 bar	G _{1/2} Bottom
PGB1001025	PGB.1001.025	0-25 bar	G _{1/2} Bottom
PGB1001040	PGB.1001.040	0-40 bar	G _{1/2} Bottom
PGB1001060	PGB.1001.060	0-60 bar	G _{1/2} Bottom
PGB1001100	PGB.1001.100	0-100 bar	G _{1/2} Bottom
PGB1001160	PGB.1001.160	0-160 bar	G _{1/2} Bottom
PGB1001600	PGB.1001.600	0-600 bar	G _{1/2} Bottom
PGB10011000	PGB.1001.1000	0-1000 bar	G _{1/2} Bottom

Panel Mounting

Part number	Supersedes	Pressure range	Connector type
PGE1001010	PGE.1001.010	0-10 bar	G _{1/2} Panel
PGE1001016	PGE.1001.016	0-16 bar	G _{1/2} Panel
PGE1001025	PGE.1001.025	0-25 bar	G _{1/2} Panel
PGE1001040	PGE.1001.040	0-40 bar	G _{1/2} Panel
PGE1001060	PGE.1001.060	0-60 bar	G _{1/2} Panel
PGE1001100	PGE.1001.100	0-100 bar	G _{1/2} Panel
PGE1001160	PGE.1001.160	0-160 bar	G _{1/2} Panel
PGE1001250	PGE.1001.250	0-250 bar	G _{1/2} Panel
PGE1001400	PGE.1001.400	0-400 bar	G _{1/2} Panel
PGE1001600	PGE.1001.600	0-600 bar	G _{1/2} Panel
PGE10011000	PGE.1001.1000	0-1000 bar	G _{1/2} Panel

Panel Mounted (3-hole flange)

Part number	Supersedes	Pressure range	Connector type
PG.1001250	PGF.1001.250	0-250 bar	G _{1/2} Panel Flange
PGF1001400	PGF.1001.400	0-400 bar	G _{1/2} Panel Flange
PGF1001010	PGF.1001.010	0-10 bar	G _{1/2} Panel Flange
PGF1001016	PGF.1001.016	0-16 bar	G _{1/2} Panel Flange
PGF1001025	PGF.1001.025	0-25 bar	G _{1/2} Panel Flange
PGF1001040	PGF.1001.040	0-40 bar	G _{1/2} Panel Flange
PGF1001060	PGF.1001.060	0-60 bar	G _{1/2} Panel Flange
PGF1001100	PGF.1001.100	0-100 bar	G _{1/2} Panel Flange
PGF1001160	PGF.1001.160	0-160 bar	G _{1/2} Panel Flange
PGF1001600	PGF.1001.600	0-600 bar	G _{1/2} Panel Flange
PGF10011000	PGF.1001.1000	0-1000 bar	G _{1/2} Panel Flange

Note 1: Part numbers featured with bold highlighted codes will ensure a 'standard' product selection.

Note 2: Alternate displayed part number selection will require you to contact Parker Filtration for availability.

*Note 3: Any subsequent changes to gauge accuracy will be notified.